

VWR[®] Ergonomic High-Performance

Instruction Manual Pipettors

- VWR EHP Fixed Volume
- VWR EHP Single-channel Variable Volume
- VWR EHP 8-channel Variable Volume
- VWR EHP 12-channel Variable Volume



This manual is available in additional languages at www.vwr.com

Table of Contents

1. Product Description	3
2. Packing	4
3. Pipettor Design	5
4. Safety Recommendations	6
5. Specifications	7
6. Pipettor Operation	10
7. Operating Instructions	14
8. Aspiration and Dispensing Instructions	16
9. Checking Pipetting Accuracy Parameters and Pipettor Recalibration	17
10. Pipettor Maintenance	22
11. Troubleshooting	23
12. Spare Parts	25
13. Technical Service	27
14. Warranty	27

1. Product Description

Fixed Volume

The VWR Ergonomic High-Performance (EHP) Fixed Volume Pipettor is a high quality volumetric instrument that eliminates the risk of erroneous volume setting. It can accommodate volumes from 5 μL to 1,000 μL depending on the model.

Nominal Volume (μL)	Cat. No. (EU)	Cat. No. (NA)
5	613-0166	83009-758
10	613-0167	83009-760
20	613-0168	83009-762
25	613-0169	83009-764
50	613-0170	83009-766
100	613-0171	83009-768
200	613-0172	83009-770
250	613-0173	83009-772
500	613-0174	83009-774
1,000	613-0175	83009-776

Variable Volume

The VWR EHP single-channel pipettor is a volumetric instrument designed to measure and transfer liquids precisely and safely. It is available in volumes from 0.1 μL to 10,000 μL .

The VWR EHP 8-channel and 12-channel pipettors are designed for microplate filling. The pipettors enable precise and simultaneous delivery of 8 or 12 preset volumes of liquid. These pipettors are available in four volume ranges: 0.5-10 μL , 5-50 μL , 20-200 μL , and 50-300 μL .

Nominal Volume (μL)	Cat. No. (EU)	Cat. No. (NA)	Range of Pipettor Volumes (μL)
Single-channel Pipettors			
2	613-5258	89079-960	0.1 - 2
10	613-5259	89079-962	0.5 - 10
20	613-5260	89079-964	2 - 20
50	613-5261	89079-966	5 - 50
100	613-5262	89079-968	10 - 100
200	613-5263	89079-970	20 - 200
250	613-5264	89079-972	50 - 250

Nominal Volume (µL)	Cat. No. (EU)	Cat. No. (NA)	Range of Pipettor Volumes (µL)
1,000	613-5265	89079-974	100 - 1,000
5,000	613-5266	89079-976	500 - 5,000
10,000	613-5267	89079-978	1,000 - 10,000

8-channel and 12-channel Pipettors

8-10	613-5250	89079-944	0.5 - 10
12-10	613-5254	89079-952	
8-50	613-5251	89079-946	5 - 50
12-50	613-5255	89079-954	
8-200	613-5252	89079-948	20 - 200
12-200	613-5256	89079-956	
8-300	613-5253	89079-950	50 - 300
12-300	613-5257	89079-958	

VWR pipettors operate using an air-cushion (i.e., the aspirated liquid does not come into contact with the shaft or plunger of the pipettor). The liquid is drawn into the disposable tip attached to the pipettor.

2. Packing

The pipettors are delivered with the following:

Description	Qty/Pk
Instruction manual	1
Quality Control certificate	1
Calibration key	1
Pipettor hanger	1
Identification labels	1
Lubricant (for single-channel pipettor)	1
Ejector cap (for pipettor models 2, 5, 10, 5,000, and 10,000 µL)	1
Filters (for pipettor models 5,000 µL and 10,000 µL)	3
Ejector spacers (for models up to 1,000 µL)	2

Filters

The 5,000 µL and 10,000 µL pipettors include a replaceable filter, fitted at the bottom of the shaft which prevents aspirated liquid from entering the shaft and contaminating the inner surface and plunger. Use of the filter is particularly important when aspirating and dispensing large volumes of liquid. The filter should be replaced if it becomes wet.

3. Pipettor Design

Model Identification

The volume range of the pipettor is shown on the pushbutton and on the tip ejector bar in multi-channel pipettors.

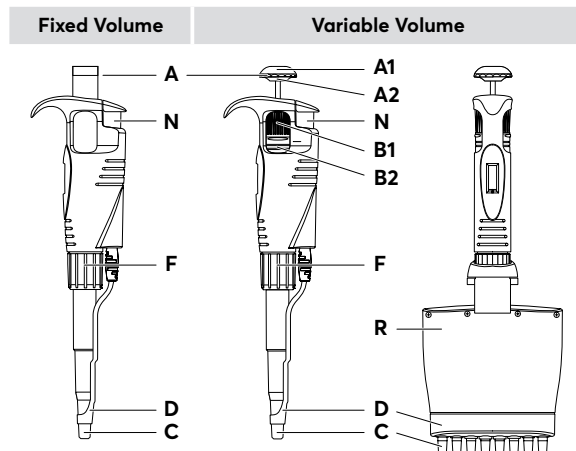

- A. Pipetting pushbutton:** Consists of 2 parts: the pushbutton (A1) and the knob (A2).
- B1. Volume adjustment knob:** Used to set the volume.
- B2. Locking Ring:** Allows the volume setting to be locked by pushing the ring upwards.
- C. Shaft:** Manufactured using high quality plastic, ensuring high chemical and mechanical strength.
- D. Tip ejector:** For multi-channel pipettors, the tips are ejected sequentially, reducing the required force.
- F. Shaft nut**
- N. Ejector pushbutton**
- R. Multi-channel manifold:** Contains a set of plungers and a set of flexible-suspension shafts, which function to reduce the force required to attach the tip.

4. Safety Recommendations

Long-term use of the pipettor relies on correct method of use. Please read and follow the instructions for use carefully. Symbols used:

 Danger, risk of injury.

NOTE Risk of damage to the pipettor or errors in pipetting.

NOTE:

- The pipettor is designed for the transfer of liquids only using the tip. Do not aspirate liquids without the tip attached. The aspirated liquid should not enter the pipettor, as it may cause damage.
- Single-use tips reduce the risk of contamination of samples.
- Keep the pipettor clean, avoiding the use of abrasive or corrosive cleaning agents (e.g., acetone).
- Keep the pipettor upright when there is liquid in the tip.
- Only using the pipettor in accordance with the manufacturer's instructions ensures the correct pipettor parameters are maintained.
- After replacing the plunger or the shaft, the pipettor should be calibrated.
- In the case of incorrect operation, the device should be cleaned in accordance with the Instructions for Use or transferred to a service point.
- Ambient operating temperature is +5°C to 45°C.
- Ambient storage conditions (in the original packaging during transport and short storage) is -25°C to 55°C.

 | When working with the pipettor:

- Follow general work safety regulations regarding hazards related to work in the laboratory.
- Take special care when pipetting aggressive substances.
- Use appropriate protective attire (e.g., clothing, goggles, and gloves).
- Avoid pointing the pipettor at yourself or others during use.
- Only use parts and accessories recommended by the manufacturer.

5. Specifications

The pipettor is a high quality instrument which offers excellent accuracy and precision. The accuracy and precision (repeatability) of the liquid volume depends on the quality of pipet tips used. The values for accuracy and precision shown in the table below were obtained using manufacturer non-filter pipet tips. Those tips are recommended for use to ensure compatibility, accuracy and precision when pipetting.

Fixed Volume

Nominal Volume (µL)	Accuracy (%)	Precision (%)	Non-filter Tips (µL)
5	± 1.0	≤ 0.8	10
10	± 0.5	≤ 0.4	10
20	± 0.8	≤ 0.4	200
25	± 0.8	≤ 0.4	200
50	± 0.8	≤ 0.4	200
100	± 0.8	≤ 0.3	200
200	± 0.6	≤ 0.3	200
250	± 0.6	≤ 0.3	1,000
500	± 0.5	≤ 0.3	1,000
1,000	± 0.4	≤ 0.3	1,000

Variable Volume

Nominal Volume (µL)	Volume (µL)	Accuracy (%)	Precision (%)	Non-filter Tips (µL)
Single-channel Pipettors				
2	Min. 0.1	±40.0	≤12.0	10
	0.2	±12.0	≤6.0	
	1	±2.7	≤1.3	
	Max. 2	±1.5	≤0.7	
10	Min. 0.5	±4.0	≤2.8	10
	1.0	±2.5	≤1.8	
	5.0	±1.0	≤0.6	
	Max. 10.0	±0.5	≤0.4	
20	Min. 2	±3.0	≤1.5	200
	10	±1.0	≤0.5	
	Max. 20	±0.8	≤0.3	
	Min. 5	±2.5	≤2.0	
50	25	±1.0	≤0.6	200
	Max. 50	±0.8	≤0.4	
	Min. 10	±1.6	≤0.80	
	50	±0.8	≤0.24	
100	Max. 100	±0.8	≤0.20	200
	Min. 20	±1.2	≤0.60	
	100	±0.8	≤0.25	
	Max. 200	±0.6	≤0.20	
200	Min. 50	±1.0	≤0.4	200
	125	±0.8	≤0.3	
	Max. 250	±0.6	≤0.3	
	Min. 100	±1.6	≤0.40	
1,000	500	±0.7	≤0.20	1,000
	Max. 1,000	±0.6	≤0.15	
	Min. 500	±1.2	≤0.50	
	1,000	±0.6	≤0.25	
5,000	2,500	±0.6	≤0.20	5,000
	Max. 5,000	±0.5	≤0.15	
	Min. 1,000	±2.5	≤0.6	
	5,000	±0.8	≤0.3	
10,000	Max. 10,000	±0.5	≤0.2	10,000

Nominal Volume (µL)	Volume (µL)	Accuracy (%)	Precision (%)	Non-filter Tips (µL)
8-channel and 12-channel Pipettors				
8 - 10 12 - 10	Min. 0.5	±10.0	≤8.0	10
	1	±8.0	≤6.0	
	5	±4.0	≤2.0	
	Max. 10	±2.0	≤1.2	
8 - 50 12 - 50	Min. 5	±4.0	≤2.5	200
	25	±3.0	≤1.2	
	Max. 50	±1.6	≤0.6	
	Min. 20	±3.0	≤1.5	
8 - 200 12 - 200	100	±1.5	≤0.8	200
	Max. 200	±1.0	≤0.6	
	Min. 50	±1.6	≤1.5	
	150	±1.2	≤1.0	
8 - 300 12 - 300	Max. 300	±1.0	≤0.6	300

The accuracy and precision were obtained gravimetrically using manufacturer tips performing at least 10 measurements of distilled water at a temperature of 20°C ± 1°C according to EN ISO 8655 standards.

The use of tips from other manufacturers or filter tips may result in incorrect liquid aspiration and require pipettor recalibration.

The design of the pipettor enables the user to recalibrate it according to the information presented in Section 9.

6. Pipettor Operation

Attaching the Tips

- Attach the correct tip corresponding to the model number displayed on the pipettor pushbutton (Section 5).
- Position the pipettor vertically when attaching tips.
- Single-channel pipettors: push the pipet tip on firmly using a slight twisting motion to ensure an airtight seal.
- Multi-channel pipettors: press the pipettor against the tips positioned in the rack box until the shaft retracts approximately 1.5mm into the manifold. The suspension system ensured even and airtight sealing of the pipet tips. The rocking motion does not have to be performed to seal the pipet tips tightly.

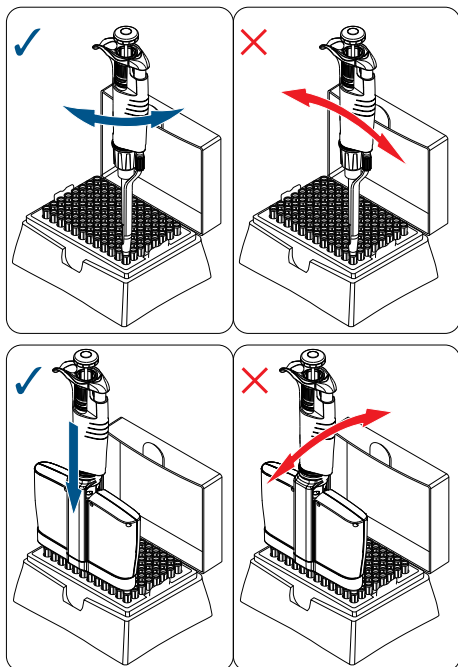

NOTE:

- Do not attach the tips with a rocking movement, as this may damage the shaft or plunger. Observe this rule particularly with single-channel pipettors of low volume range.

- Never draw liquids directly into the pipettor without the tip attached.

Adjusting the tip ejector

The tip ejector can be adjusted by the user and can accommodate most types of tip available on the market. When using narrow tubes, it may be necessary to remove the tip ejector.

2-1,000 μL pipettors

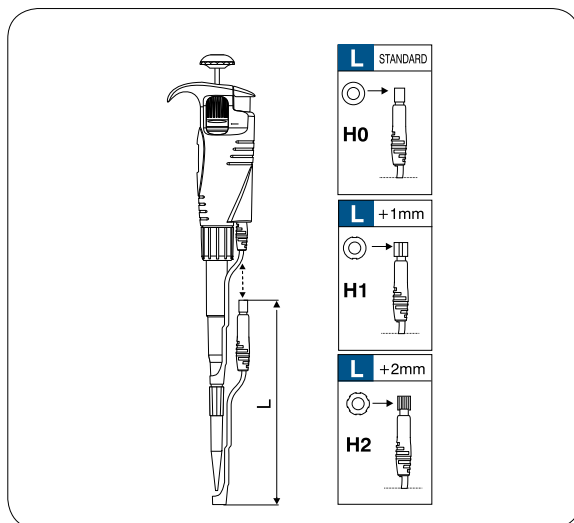

1. Tip ejector disassembly

- Press the tip ejector pushbutton.
- Slide the ejector from the plastic arbor.

2. Tip ejector assembly

- Press the tip ejector pushbutton.
- Line the metal tip ejector up with the plastic arbor.
- Slide the ejector on the arbor.

3. Tip ejector adjustment

- Remove the tip ejector pushbutton.
- Remove "H0" spacer that is inserted on the ejector arbor. To increase the ejector length use "H" spacers, which allow for regulating the length of tip ejector by +1 mm (H1) or +2 mm (H2). The outside shape identifies the spacers.

5,000 and 10,000 μ L pipettors

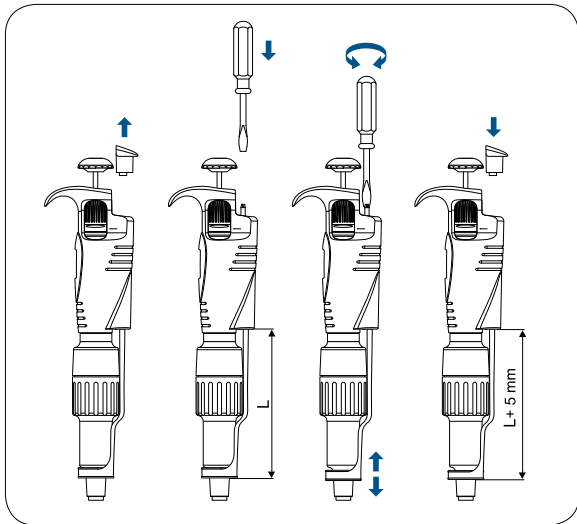

1. Tip ejector disassembly

- Remove the tip ejector pushbutton.
- Using a screwdriver, turn the metal arbor counter-clockwise to unscrew the ejector from the arbor.
- Release the ejector.

2. Tip ejector assembly

- Remove the tip ejector pushbutton.
- Using a screwdriver, turn the metal arbor clockwise to secure the ejector and adjust its length.
NOTE: Leave a space of at least 1 mm between the shaft and tip ejector collar.

3. Tip ejector adjustment

- Remove the ejector pushbutton.
- Use the screwdriver to increase or decrease the ejector length.
- Following ejector assembly or adjustment, ensure the ejector pushbutton is relocated.

If the tip ejector cannot be adjusted sufficiently, or if the diameter of the ejector is insufficient to eject the tip, it may be necessary to attach the ejector cap "M" to the ejector.

In 2 and 10 μ L pipettors place the cap, supplied with the pipettor, on the bottom of the pipettor shaft and slide the cap upwards to the bottom of the tip ejector.

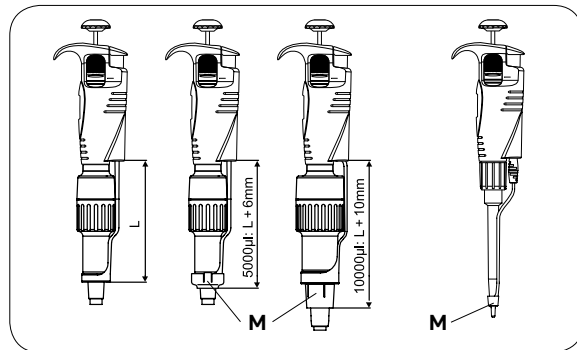

Volume Setting

Variable Volume Pipettors

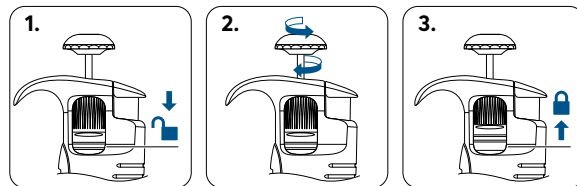

1. To enable volume selection, set the locking ring to the lower position.
2. Aspiration volume can be set by either turning the pipetting pushbutton knob, or the adjustment knob. The volume setting is displayed as a three digit counter, which should be read from top to bottom. The smallest volume increment is printed on the bottom counter drum.
3. After the volume has been set, set the locking ring to the upper position to avoid inadvertent changing of volume.

Examples of counter indications

The decimal point in the volume of aspirated liquid (μL or mL) is indicated by change in color of digits. Black digits represent integer numbers, and red digits represent decimal fractions (sizes up to 20 μL).

1	0	0
2	3	7
5	5	5

Volume Ranges	0.1-2 μL	5-50 μL	100-1,000 μL
Set Volume	1.25 μL	35 μL	750 μL (0.75 mL)
Increment	0.002 μL	0.2 μL	2.0 μL

For maximum accuracy, the set volume must be approached from a higher value by decreasing counter readings. Before reaching the desired value, reduce the speed of turning the adjustment knob to avoid inadvertently exceeding the desired value.

7. Operating Instructions

Observing the following recommendations will ensure maximum possible accuracy and precision of liquid sampling.

- During operation, the volume setting should be locked, with black adjustment knob in the lower position.
- Ensure smooth and slow operation of the pipettor.
- Immersion of the tip into the sample liquid should be kept to a minimum depth, which should remain constant during aspiration. The recommended immersion depths are given in the table below:

Model Volume Range (μL)	Immersion Depth (mm)
0.1-1	≤ 1
1-100	2-3
101-1,000	2-4
5,000	3-6
10,000	5-7

- The pipettor should be held in a vertical position.
- The pipet tip should be changed whenever the volume setting is altered, and when a different liquid is to be aspirated.
- The pipet tip should be changed if a droplet remains on the end of the tip from the previous pipetting operation.
- Each new pipet tip should be pre-rinsed with the liquid to be pipetted.
- Liquid should never enter the pipettor shaft. To prevent this:
 - Press and release the pushbutton slowly and smoothly.
 - Never turn the pipettor upside down.
 - Never lay the pipettor on its side when there is liquid in the tip.
- Never force the volume setting beyond the recommended limits.
- When pipetting liquids with a different temperature from the ambient temperature, it is recommended to pre-rinse the tip several times prior to use.
- Do not pipettor liquids with temperatures above 70°C.

NOTE: When pipetting acids or corrosive solutions which emit vapors, it is recommended to disassemble the shaft and rinse the plunger and O-ring with distilled water after finishing the pipetting operation.

8. Aspiration and Dispensing Instructions

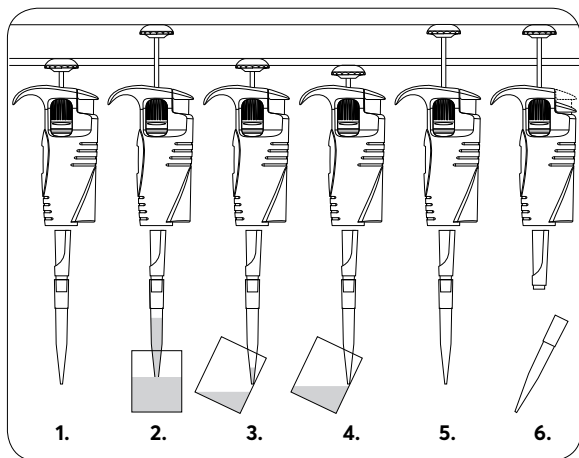

Aspirating Liquid

1. Press the pushbutton to the first stop point.
Holding the pipettor vertically, immerse the pipet tip into the sample liquid to the recommended depth (for recommended values see Section 7). If the pipet tip is not immersed to the recommended depth or if the pipetting pushbutton is rapidly released, air may enter the pipet tip.
2. Release the pipetting pushbutton slowly and smoothly to aspirate the sample. Wait one second and then withdraw the pipet tip from the liquid.

CAUTION: Do not touch the used tip.

Dispensing Liquid

3. Place the end of the pipet tip against the inside wall of the vessel at an angle of 10° to 40°. Press the pushbutton smoothly to the first stop. Wait one second.
4. Press the pushbutton to the second stop to expel any remaining liquid. While keeping the pushbutton depressed, remove the pipettor from the vessel by drawing the pipet tip against the inside surface of the vessel.
5. Release the pushbutton to its starting position.
6. Eject the pipet tip by pressing the tip ejector pushbutton.

 Remember to change the pipet tip whenever a different type of liquid is to be sampled.

Aspirating High-density Liquids

When pipetting liquids of higher viscosity or lower surface tension than water (e.g., sera or organic solvents), a film of liquid may be formed on the inside of the pipet tip which may produce erroneous results. As the film remains relatively constant in successive pipetting operations with the same tip, this error can be eliminated by pre-rinsing the tip and allowing a film to form before transferring the first sample. This is achieved by aspirating a sample and dispensing it back into the same vessel. Allowing a film to form prior to sampling ensures optimal accuracy and repeatability.

This pre-rinsing operation should be repeated when the volume to be aspirated is changed or when a new pipet tip is used.

NOTE: Normally the degree of error resulting from viscous liquids is negligible if pipetting is performed slowly and carefully, however can be minimized further by holding the pipet tip in position for at least 2 seconds after aspiration to allow the liquid time to react to the change in pressure before it is dispensed.

If the above method does not result in accurate values, recalibrate the pipettor in accordance with Section 9.

It is recommended to record recalibration and correction values, in order to facilitate reverse calibration to a standard liquid.

Filters

The 5,000 µL and 10,000 µL pipettors include a replaceable filter (L), fitted at the bottom of the shaft which prevents aspirated liquid from entering the shaft and contaminating the inner surface and plunger. Use of the filter is particularly important when aspirating and dispensing large volumes of liquid. The filter should be replaced if it becomes wet.

9. Checking Pipetting Accuracy Parameters and Pipettor Recalibration

The pipettors have been factory-calibrated using gravimetric methods with manufacturer pipet tips and distilled water, in accordance with ISO 8655 guidelines for the maximum (nominal) liquid volume drawn by the pipettor and for 10% of the maximum or minimum liquid volume according to the values given (Section 5).

The pipettors are designed to enable recalibration and adaptation to different pipetting techniques and liquid properties (e.g., temperature, density, and viscosity).

Periodic checks of the operation of the pipettor are recommended at least once per year. Frequency of checks should be increased depending on workload, sterilization or autoclave processes, and frequency of replacement of component parts.

If during pipettor operation the accuracy error (the difference between the real aspirated volume and the preset volume) exceeds the permissible value given in the table in Section 5, pipettor recalibration should be carried out.

Recalibration of the pipettor involves setting the counter to the value of the liquid volume obtained by weighing. Recalibration of the pipettor is valid only for one liquid volume drawn by the pipettor.

The recommended volume for recalibration is 10% of the maximum (nominal) value or minimum volume depending on which of these values is greater. See table on page 18 for more details.

Parameters for Checking the Pipetting Accuracy

The pipetting accuracy is influenced by factors such as: tips used, characteristics of the pipetted liquid (density, viscosity), and operating conditions (ambient temperature, pressure).

To determine the accuracy error of the pipettor, the following conditions should be met:

- Ambient temperature and temperature of the pipettor, pipet tips, and liquid should be within the range of 20°C to 25°C and stabilized during weighing within $\pm 0.5^\circ\text{C}$.
- Measurements should be conducted using distilled water.
- Balance sensitivity should be suitable for the volume "V" to be measured:

Volume Checked (V, μL)	Balance Sensitivity (mg)
$0.1 \leq V \leq 10$	0.001
$10 \leq V \leq 100$	0.01
$100 \leq V \leq 1,000$	0.1
$V > 1,000$	0.1

- When calculating the liquid volume aspirated by the pipettor, the conversion factor (Z) ($\mu\text{L}/\text{mg}$) for distilled water or a liquid with comparable density should be taken into account. Sample values of conversion factors are given in the following table.

Temperature ($^\circ\text{C}$)	Pressure (kPa)		
	95.0	101.3	105.0
20	1.0028	1.0029	1.0029
21	1.0030	1.0031	1.0031
22	1.0032	1.0033	1.0033
23	1.0034	1.0035	1.0036
24	1.0037	1.0038	1.0038
25	1.0039	1.0040	1.0040

See ISO 8655 for the full table of conversion factors (Z).

NOTE: Pipetting should be performed in accordance with guidance described in Sections 7 and 8.

Checking the Pipetting Accuracy Parameters

Fixed Volume

Nominal volume (μL)	Permissible values (μL)		Volume Change ΔV (μL) for a Turn of a Calibration Key by	
			1 Turn	1 Increment
5	4.95	5.05	0,33	0.0137
10	9.95	10.05	0,33	0.0137
20	19.84	20.16	0,63	0.0262
25	24.80	25.20	0,63	0.0262
50	49.60	50.40	2,50	0.104
100	99.20	100.80	2,50	0.104
200	198.80	201.20	6,30	0.262
250	248.50	251.50	25,0	1.04
500	497.50	502.50	25,0	1.04
1,000	996.00	1,004.00	25,0	1.04

Variable Volume

- Set the preset volume depending on the pipettor volume according to the following table.

Nominal volume (μL)	Preset volume (μL)	Permissible values (μL)	Volume Change ΔV (μL) for a Turn of a Calibration Key by	
			1 Turn	1 Increment
Single-channel Pipettors				
2	0.2	0.176 - 0.224	0.06	0.0025
10	1	0.975 - 1.025	0.33	0.0137
20	2	1.94 - 2.06	0.63	0.0262
50	5	4.875 - 5.125	2.50	0.104
100	10	9.84 - 10.16	6.30	0.262
200	20	19.76 - 20.24	25.00	1.04
250	50	49.5 - 50.5	125.00	5.2
1,000	1,000	975 - 1,025	250.00	10.4
8-channel and 12-channel Pipettors				
10	1	0.92 - 1.08	0.33	0.0137
50	5	4.8 - 5.2	1.67	0.070
200	20	19.4 - 20.6	6.30	0.262
300	50	49.2 - 50.8	10.00	0.42

- Perform 10 aspirations, and calculate the average value in (mg).
- Calculate the volume in (μL) by multiplying the value in (mg) by the conversion factor Z (μL/mg).

If the average aspirated volume exceeds the permissible values of the range, the pipettor should be recalibrated.

Pipettor Recalibration

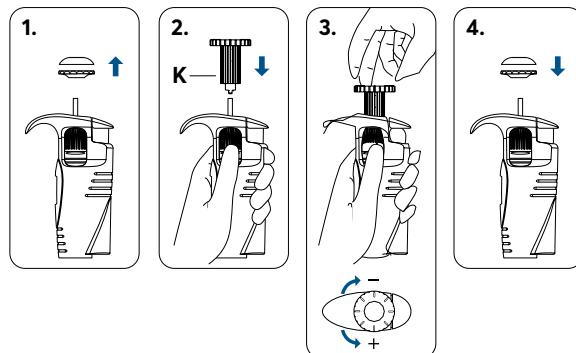

- Remove the pipetting pushbutton.
CAUTION: In the variable pipettors the pipetting pushbutton consists of 2 parts: the knob and the pushbutton. After removal of the pushbutton, both parts are separated.
- Insert the calibration key into the calibration screw.
CAUTION: In variable pipettors hold the volume setting knob to prevent rotation.
- Turn the key clockwise to reduce the aspirated volume, or counter-clockwise to increase the aspirated volume. Use the values given in the above table to precisely adjust the volume.
- Remove the key and replace the pipetting pushbutton by first replacing the knob, then the pushbutton.

Determine the average aspirated volume. The average volume should be within the permissible range given in the table. If the volume exceeds the values stated, the recalibration procedure should be repeated.

When pipetting liquids with physical properties considerably different from those of water, follow the guidance given in Section 5.

More information on the calibration procedure can be found at www.vwr.com

10. Pipettor Maintenance

Depending on the applications and intensity of use, the pipettor requires periodic maintenance. The components exposed to corrosive vapors, such as shaft elements, should be regularly checked and cleaned.



Do not use sharp tools for pipettor maintenance. It may cause damage to the device and affect the user's safety.

Cleaning

External surfaces of the pipettor such as the pushbutton, ejector pushbutton, handgrip, shaft nut, and adjustment knob may be cleaned using a cloth dampened in isopropyl alcohol. The remaining parts removed from the pipettor during pipettor disassembly may be washed with distilled water or isopropyl alcohol.

NOTE: Before using cleaning agents other than those recommended by the manufacturer, check the compatibility charts and consider chemical resistance of the following plastics which form components of the pipettor: PP, PC, POM, PA, PPS, PVDF.

Sterilization

Sterilization using an autoclave

The pipettor can be sterilized in an autoclave at 121°C for 20 minutes. Sterilization under other conditions may cause damage to the pipettor. It is recommended to:

- Unscrew the shaft nut slightly in the 2-1,000 µL pipettors, and unscrew the shaft slightly in the 5,000 and 10,000 µL. After autoclaving these parts should be screwed tight again.
- Set the locking ring to the lower (unlocked) position prior to sterilization.
- Sterilize the pipettors using an autoclave with an initial vacuum and drying cycle.
- After sterilization, the pipettor should be dried and cooled to room temperature.
- The shaft of the 5,000 and 10,000 µL models should be autoclaved without the filter.

Precision and accuracy should not alter if the pipetting processes including autoclaving are carried out as described in this manual. If a change in accuracy occurs, it is recommended to:

- Check the calibration of the pipettor after the first, third, and fifth autoclaving cycles and then after every 10 autoclaving cycles.

Ultra Violet (UV) Sterilization

The pipettors are UV resistant. The distance from the radiation source to the exposed element of the pipettor should be at least 50 cm. Prolonged or intense UV exposure can cause discoloration of pipettor parts but does not affect its performance.

11. Troubleshooting

If a problem is encountered during pipettor operation, use the following table to identify and eliminate the fault following the instructions provided. Replacement of parts should be required only occasionally and should not be required with normal pipettor use.

Problem	Cause	Solution
Droplets of liquid remain in the pipet tip.	The pipet tip is emptied too fast.	Decrease the speed of pressing the pipettor pushbutton.
	The pipet tip wettability has increased due to extensive use.	Replace the tip with a new one.
Droplets of air appear in the liquid aspirated into the pipet tip.	The pipet tip immersion depth is too shallow.	Immerse the tip to the recommended depth according to the instructions.
	The pipet tip is incorrectly pressed onto the pipettor shaft.	Press the pipettor tip firmly onto the pipettor.
	The tip is damaged or worn out due to extensive use.	Replace the tip with a new one.
The pipettor incorrectly aspirates the liquid or the liquid drops out from the tip.	The pipettor tip is incorrectly pressed onto the pipettor shaft.	Press the pipet tip firmly onto the pipettor.

Problem	Cause	Solution
The pipettor incorrectly aspirates the liquid or the liquid drops out from the tip.	The shaft surface is damaged or contaminated at the sealing site.	Clean the shaft or replace it with a new one.
The pipettor incorrectly aspirates the liquid or the liquid drops out from the tip.	The plunger or the O-ring is damaged due to prolonged aspiration of corrosive liquids.	Disassemble the shaft set; wash the shaft, the plunger and the seal (Section 10: Cleaning). Replace the elements with new ones if necessary. Apply a small amount of lubricant onto the plunger and reassemble the set in the correct order.
	The inside of the pipettor is contaminated.	
	The sealing elements are not sufficiently lubricated.	
Uneven work of the pipetting set, the pipetting pushbutton gets blocked.	The inside of the pipettor is contaminated due to aspiration of corrosive substances.	Unscrew the shaft set, wash the parts. Replace the elements with new ones if necessary. Apply a small amount of lubricant on the plunger and reassemble the set in the correct order.
	The inside of the pipettor is contaminated due to the liquid entering the pipettor.	
	The sealing elements are not sufficiently lubricated, e.g. after repeated autoclaving procedures.	
Incorrect aspiration.	Liquid with properties other than water (density, viscosity).	Calibrate the pipettor using the liquid which is to be pipetted.
	Tips with a filter with increased flow resistance.	Calibrate the pipettor using the tips which are to be used for pipetting.

If the problem persists after carrying out the above steps, contact our regional representative.

Before returning the pipettor, please ensure the pipettor is completely free of any chemical, radioactive, or micro-biological contamination which could pose a threat during transport and repair.

12. Spare Parts

Contact our Customer Service to inquire about availability of spare parts. Pipettor model and name of the part required should be specified. The most common parts are depicted below.

NOTE: The replacement of the plunger requires conducting the calibration procedure according to Section 9.

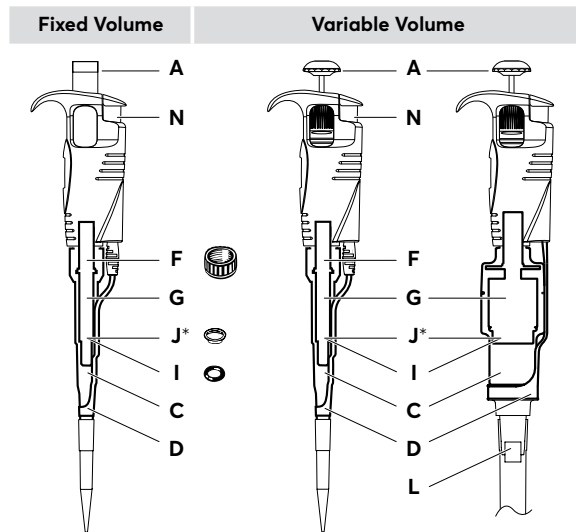

*Seal (J) used only in models 2, 5,000 and 10,000 μ L

Item	Description	Model Variable	Model Fixed	Cat. No.	Qty /Pk
B	Volume adjustment knob set	All	-	SP29327	1
		2	-	SP19131	1
		10	5, 10	SP19132	1
		20	20, 25	SP19133	1
C, I, J*	Shaft with O-ring and seal	50, 100	50, 100	SP19134	1
		200, 250	200	SP19135	1
		1,000	250-1,000	SP19136	1
		5,000	-	SP19138	1
		10,000	-	SP19139	1

		2, 10	5, 10	SP29307	1	
		20	20, 25	SP29308	1	
		50, 100	50, 100	SP29309	1	
D	Tip ejector	200, 250	200	SP29310	1	
		1,000	250-1,000	SP29322	1	
		5,000	-	SP19452	1	
		10,000	-	SP19453	1	
F	Shaft nut	2-1,000	All	SP29435	1	
		2	-	SP19381	1	
		10	5, 10	SP19382	1	
		20	20, 25	SP19383	1	
G	Piston assembly	50, 100	50, 100	SP19384	1	
		200, 250	200	SP19385	1	
		1,000	250-1,000	SP19386	1	
		5,000	-	SP19388	1	
		10,000	-	SP19389	1	
I, (J)	O-ring (and seal*)	2	-	SP19101	10	
		10	5, 10	SP19102	10	
		20	20, 25	SP19103	10	
		50, 100	50, 100	SP19104	10	
		200, 250	200	SP19105	10	
		1,000	250-1,000	SP19106	10	
		5,000	-	SP19108	5	
		10,000	-	SP19109	5	
K	Calibration key	All	-	SP29334	1	
		-	All	SP9233	1	
L	Shaft filter	5,000, 10,000	-	SP19476	10	
M	Tip ejector cap	2, 10	5, 10	SP19378	3	
		5,000	-	SP19466	3	
		10,000	-	SP19467	3	
S	Shelf clip	All	All	SP19483	1	

*Seal (J) used only in models 2, 5,000 and 10,000 µL

13. Technical Service

Web Resources

Visit the VWR website at www.vwr.com for:

- Complete technical service contact information
- Access to the VWR Online Catalogue, and information about accessories and related products
- Additional product information and special offers

Contact us

For information or technical assistance contact your local VWR representative or visit www.vwr.com

14. Warranty

VWR warrants that this product will be free from defects in material and workmanship for a period of three (3) years from date of delivery. If a defect is present, VWR will, at its option and cost, repair, replace, or refund the purchase price of this product to the customer, provided it is returned during the warranty period. This warranty does not apply if the product has been damaged by accident, abuse, misuse, or misapplication, or from ordinary wear and tear. If the required maintenance and inspection services are not performed according to the manuals and any local regulations, such warranty turns invalid, except to the extent, the defect of the product is not due to such non-performance.

Items being returned must be insured by the customer against possible damage or loss. This warranty shall be limited to the aforementioned remedies.

IT IS EXPRESSLY AGREED THAT THIS WARRANTY WILL BE IN LIEU OF ALL WARRANTIES OF FITNESS AND IN LIEU OF THE WARRANTY OF MERCHANTABILITY.

For additional product or technical information, visit www.vwr.com or contact your local sales office.

Austria

VWR International GmbH
Graumannsgasse 7
1150 Vienna
Tel.: +43 01 97 002 0
Email: info.at@vwr.com

Belgium

VWR International bv
Researchpark Haasrode
2020
Geldenaaksebaan 464
3001 Leuven
Tel.: +32 016 385 011
Email: vwr.be@vwr.com

China

VWR (Shanghai) Co., Ltd
Bld.No.1, No.3728 Jinke Rd,
Pudong New District
Shanghai, 201203- China
Tel.: 400 821 8006
Email: info_china@vwr.com

Czech Republic

VWR International s. r. o
Veetee Business Park
Pražská 442
CZ - 281 67 Stržbrná Skalice
Tel.: +420 321 570 321
Email: info.cz@vwr.com

Denmark

VWR International A/S
Tobaksvejen 21
2860 Søborg
Tel.: +45 43 86 87 88
Email: info.dk@vwr.com

Finland

VWR International Oy
Valimotie 17-19
00380 Helsinki
Tel.: +358 09 80 45 51
Email: info.fi@vwr.com

France

VWR International S.A.S.
Immeuble Estréo
1-3 rue d'Aurion
93114 Rosny-sous-Bois cedex
Tel.: 0 825 02 30 30*
(national)
Tel.: +33 (0) 1 45 14 85 00
(international)
Email: info.fr@vwr.com
*0,18 € TTC/ min + prix appel

Germany

VWR International GmbH
Hilpertstraße 20a
D - 64295 Darmstadt
Freecall: 0800 702 00 07
Tel.: +49 (0) 6151 3972 0
(international)
Email: info.de@vwr.com

Hungary

VWR International Kft.
Simon László u. 4.
4034 Debrecen
Tel.: +36 (52) 521-130
Email: info.hu@vwr.com

India

VWR Lab Products Private
Limited No.139.
BDA Industrial Suburb,
6th Main, Tumkur Road,
Peenya Post, Bangalore,
India - 560058
Tel.: +91 80 28078400
Email: vwr_india@vwr.com

Ireland

VWR International Ltd
Orion Business Campus
Northwest Business Park
Ballycoolin
Dublin 15
Tel.: +353 01 88 22 222
Email: sales.ie@vwr.com

Italy

VWR International S.r.l.
Via San Giusto 85
20153 Milano (MI)
Tel.: +39 02-3320311
Email: info.it@vwr.com

Korea

Avantor Performance
Materials Korea Ltd
2F ACE Gwanggyo Tower I
Daehak 4ro 17
Yeongtong-gu Suwon
Korea 16226
Tel.: +82 31 645 7250
Email: saleskorea@avantorsciences.com

Middle East & Africa

VWR International FZ-LLC
Office 203,
DSP Lab Complex,
Dubai Science Park
Dubai, United Arab Emirates
Tel.: +971 4 5573271
Email: info.mea@vwr.com

The Netherlands

VWR International B.V.
Postbus 8198
1005 AD Amsterdam
Tel.: +31 020 4808 400
Email: info.nl@vwr.com

Norway

VWR International AS
Brynsalleen 4
0667 Oslo
Tel.: +47 22 90 00 00
Email: info.no@vwr.com

Poland

VWR International Sp. z o.o.
Limbowa 5
80-175 Gdansk
Tel.: +48 058 32 38 200
Email: info.pl@vwr.com

Portugal

VWR International - Mat. de
Laboratório, Soc. Unipessoal,
Lda Edifício Ramazzotti
Avenida do Forte 6,
P-1.09 e P-1.10
2790-072 Carnaxide
Tel.: +351 21 3600 770
Email: info.pt@vwr.com

Singapore

VWR Singapore Pte Ltd
18 Gul Drive
Singapore 629468
Tel.: +65 6505 0760
Email: sales.sg@vwr.com

Spain

VWR International
EuroLab S.L.U.
C/ Tecnología 5-17
A-7 Llinars Park
08450 - Llinars del Vallès
Barcelona
Tel.: +34 902 222 897
Email: info.es@vwr.com

Sweden

VWR International AB
Fagerstagatan 18b
163 94 Stockholm
Tel.: +46 08 621 34 20
Email: info.se@vwr.com

Switzerland

VWR International GmbH
Lerzenstrasse 16/18
8953 Dietikon
Tel.: +41 044 745 13 13
Email: info.ch@vwr.com

UK

VWR International Ltd
Customer Service Centre
Hunter Boulevard
Magna Park
Lutterworth
Leicestershire
LE17 4XN
Tel.: +44 (0) 800 22 33 44
Email: uksales@vwr.com

Manufactured for VWR International,
LLC 100 Matsonford Rd, Radnor, PA 19087

Version 1

Made in Poland