

Manual

Sample Divider PT100

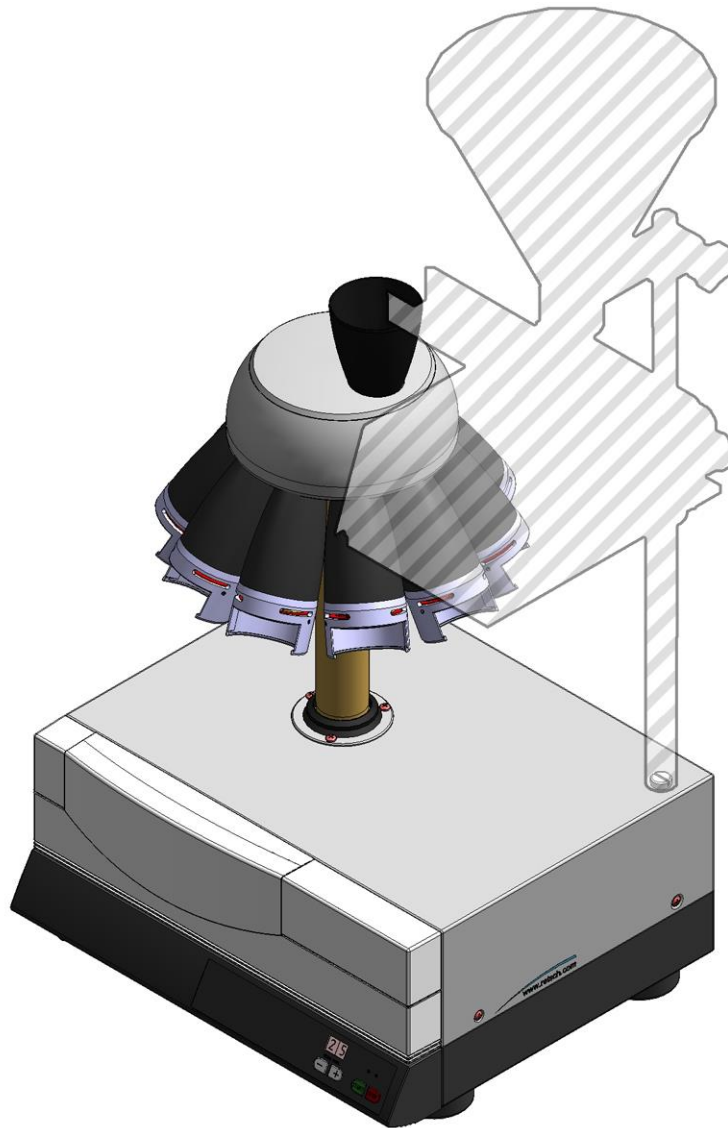

Translation

Retsch[®]

Copyright

© Copyright by
Retsch GmbH
Haan, Retsch-Allee 1-5
D-42781 Haan
Federal Republic of Germany

1	Notes on the Operating Manual	5
1.1	Explanations of the safety warnings.....	6
1.2	General safety instructions.....	7
1.3	Repairs.....	9
2	Confirmation	10
3	Transport, scope of delivery, installation	12
3.1	Packaging.....	12
3.2	Transport	12
3.3	Temperature fluctuations and condensed water.....	12
3.4	Conditions for the place of installation	12
3.5	Installation of the machine.....	12
3.6	Type plate description	12
3.7	Electrical connection	13
4	Technical data	13
4.1	Use of the machine for the intended purpose.....	13
4.2	Emissions	14
4.3	Degree of protection	14
4.4	Drive output.....	14
4.5	Rotation speed	14
4.6	Rated power	15
4.7	Feed size	15
4.8	Receptacle volume	15
4.9	Dimensions and weight	15
4.10	Required floor space.....	17
5	Operating the machine	18
5.1	Views of the Instrument.....	18
5.2	Overview table of the parts of the device.....	19
5.3	Operating elements and displays	20
5.4	Overview Table of the Operating Elements and the Display.....	20

5.5	Mounting the dividing head/dg_bm "text_mod_1315215336450_0001">	20
5.6	Inserting sample vessel.....	21
5.6.1	Inserting the sample container into the quick-release sample outlet	22
5.7	Switching On and Off.....	23
5.8	Starting, Interrupting, Stopping.....	23
5.8.1	Starting	23
5.8.2	Interrupting	23
5.8.3	Stopping.....	23
5.9	Process Run Duration	24
5.9.1	Process run times	24
5.9.2	Continuous run	24
5.10	Attaching vibratory feeder	24
5.11	Creating interface connection	26
5.12	Starting device and vibratory device simultaneously.....	28
5.13	Replacing the machine fuses	29
6	Cleaning and service	29
7	Fault messages	30
8	Disposal	31
9	Index.....	32
	Appendix	following pages

1 Notes on the Operating Manual

This operating manual is a technical guide on how to operate the device safely and it contains all the information required for the areas specified in the table of contents. This technical documentation is a reference and instruction manual. The individual chapters are complete in themselves.

Familiarity (of the respective target groups defined according to area) with the relevant chapters is a precondition for the safe and appropriate use of the device.

This operating manual does not contain any repair instructions. If faults arise or repairs are necessary, please contact your supplier or get in touch with Retsch GmbH directly.

Application technology information relating to samples to be processed is not included but can be read on the Internet on the respective device's page at www.retsch.com.

Changes

Subject to technical changes.

Copyright

Disclosure or reproduction of this documentation, use and disclosure of its contents are only permitted with the express permission of Retsch GmbH.

Infringements will result in damage compensation liability.

1.1 Explanations of the safety warnings

In this Operating Manual we give you the following safety warnings

Serious injury may result from failing to heed these safety warnings. We give you the following warnings and corresponding content.

 **WARNING**

Type of danger / personal injury

Source of danger

- Possible consequences if the dangers are not observed.
 - **Instructions on how the dangers are to be avoided.**
-

We also use the following signal word box in the text or in the instructions on action to be taken:

 **WARNING**

Moderate or mild injury may result from failing to heed these safety warnings. We give you the following warnings and corresponding content.

 **CAUTION**

Type of danger / personal injury

Source of danger

- Possible consequences if the dangers are not observed.
 - **Instructions on how the dangers are to be avoided.**
-

We also use the following signal word box in the text or in the instructions on action to be taken:

 **CAUTION**

In the event of possible **property damage** we inform you with the word “Instructions” and the corresponding content.

NOTICE

Nature of the property damage

Source of property damage

- Possible consequences if the instructions are not observed.
 - **Instructions on how the dangers are to be avoided.**
-

We also use the following signal word in the text or in the instructions on action to be taken:

NOTICE

1.2 General safety instructions

 **CAUTION**

Read the Operating Manual

Non-observance of these operating instructions

- The non-observance of these operating instructions can result in personal injuries.
- **Read the operating manual before using the device.**
- **We use the adjacent symbol to draw attention to the necessity of knowing the contents of this operating manual.**



Target group : All persons concerned with the machine in any form

This machine is a modern, high performance product from Retsch GmbH and complies with the state of the art. Operational safety is given if the machine is handled for the intended purpose and attention is given to this technical documentation.

You, as the owner/managing operator of the machine, must ensure that the people entrusted with working on the machine:

- have noted and understood all the regulations regarding safety,
- are familiar before starting work with all the operating instructions and specifications for the target group relevant for them,
- have easy access always to the technical documentation for this machine,
- and that new personnel before starting work on the machine are familiarised with the safe handling of the machine and its use for its intended purpose, either by verbal instructions from a competent person and/or by means of this technical documentation.

Improper operation can result in personal injuries and material damage. You are responsible for your own safety and that of your employees.

Make sure that no unauthorised person has access to the machine.

 **CAUTION**

Changes to the machine

- Changes to the machine may lead to personal injury.
- **Do not make any change to the machine and use spare parts and accessories that have been approved by Retsch exclusively.**

NOTICE

Changes to the machine

- The conformity declared by Retsch with the European Directives will lose its validity.
- You lose all warranty claims.
- **Do not make any change to the machine and use spare parts and accessories that have been approved by Retsch exclusively.**

2 Confirmation

This operating manual contains essential instructions for operating and maintaining the device which must be strictly observed. It is essential that they be read by the operator and by the qualified staff responsible for the device before the device is commissioned. This operating manual must be available and accessible at the place of use at all times.

The user of the device herewith confirms to the managing operator (owner) that (s)he has received sufficient instructions about the operation and maintenance of the system. The user has received the operating manual, has read and taken note of its contents and consequently has all the information required for safe operation and is sufficiently familiar with the device.

As the owner/managing operator you should for your own protection have your employees confirm that they have received the instructions about the operation of the machine.

I have read and taken note of the contents of all chapters in this operating manual as well as all safety instructions and warnings.

User

Surname, first name (block letters)

Position in the company

Signature

Service technician or operator

Surname, first name (block letters)

Position in the company

Place, date and signature

3 Transport, scope of delivery, installation

3.1 Packaging

The packaging has been adapted to the mode of transport. It complies with the generally applicable packaging guidelines.

3.2 Transport

NOTICE

Transport

- Mechanical or electronic components may be damaged.
 - **The machine may not be knocked, shaken or thrown during transport.**
-

3.3 Temperature fluctuations and condensed water

NOTICE

Temperature fluctuations

The machine may be subject to strong temperature fluctuations during transport (e.g. aircraft transport)

- The resultant condensed water may damage electronic components.
 - **Protect the machine from condensed water.**
-

3.4 Conditions for the place of installation

NOTICE

Ambient temperature

- Electronic and mechanical components may be damaged and the performance data alter to an unknown extent.
 - **Do not exceed or fall below the permitted temperature range of the machine (5°C to 40°C / ambient temperature).**
-

3.5 Installation of the machine

Installation height: maximum 2000 m above sea level

3.6 Type plate description

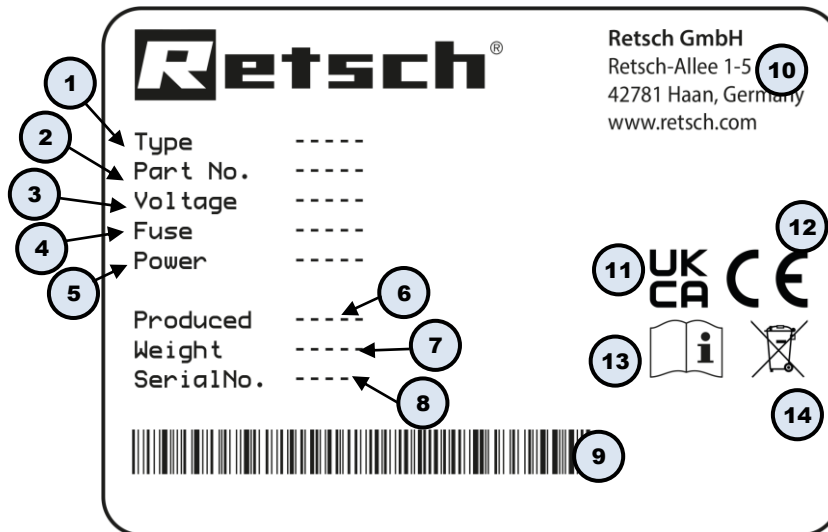

Fig. 1: Type plate

- 1 Device designation
- 2 Part number
- 3 Power version, Mains frequency
- 4 Fuse type and fuse strength
- 5 Capacity, Amperage
- 6 Year of production
- 7 Weight
- 8 Serial number
- 9 Bar code
- 10 Manufacturer's address
- 11 UKCA marking
- 12 CE marking
- 13 Safety warning: Read the manual
- 14 Disposal label

① In the case of queries please provide the device designation (1) or part number (2), as well as the serial number (8) of the device.

3.7 Electrical connection

⚠ WARNING

When connecting the power cable to the mains supply, use an external fuse that complies with the regulations applicable to the place of installation .

- Please check the type plate for details on the necessary voltage and frequency for the device.
- Make sure the levels agree with the existing mains power supply.
- Use the supplied connection cable to connect the device to the mains power supply.

4 Technical data

4.1 Use of the machine for the intended purpose



Risk of explosion or fire

- On account of its design, the device is not suitable for use in hazardous (potentially explosive) atmospheres.
- **Do not operate the device in a hazardous atmosphere.**

This device is suitable for the representative division and reduction of free-flowing, dispersed bulk material (Powder or Granulate) with a grain size of up to a maximum 10 mm.

It is possible to divide into 6, 8 or 10 representative sub-samples. When using the 10-outlet dividing head, the maximum feed quantity amounts to 5,000cm³. 10 individual samples in glass bottles with a maximum of 500cm³ volume each can be held.

For a precise division of the sample it is recommendable to feed the sample uniformly and continuously through a Retsch vibratory feeder.

NOTICE

Area of use of the machine

- This machine is a laboratory machine designed for 8-hour single-shift operation.
- **This machine may not be used as a production machine nor is it intended for continuous operation.**

4.2 Emissions

Noise data

Noise measurement in conformance to DIN 45635-31-01-KL3

The noise characteristics are also influenced by the properties of the sample.

Example idle speed

Workplace-related emission level LpAeq = 35.3 dB(A)

Example quartz

Workplace-related emission level LpAeq = 36.1 dB(A)

Operating conditions:

Dividing ratio = 8-outlet dividing head made of aluminium

Container = 8 wide-mouth bottles

Material to be divided = quartz

4.3 Degree of protection

IP40

4.4 Drive output

Stepper motor

4.5 Rotation speed

Driving head speed:

110 rpm at 50/60Hz ($\pm 3 \text{ min}^{-1}$)

4.6 Rated power

100V AC – 240 V AC 50/60Hz

65 watts / 1.6A

4.7 Feed size

- max. 10 mm for the 6-, 8- and 10-outlet dividing head large
- max. 5 mm for the 8-outlet dividing head small

4.8 Receptacle volume

The maximum holding capacity is 5 litres.

(Dividing head with 10 sample outlets and 10 sample vessels, each with a holding capacity of 500 ml)

The minimum filling volume is 180 ml.

(Dividing head with 6 sample outlets and 6 sample vessels, each with a holding capacity of 30 ml)

4.9 Dimensions and weight

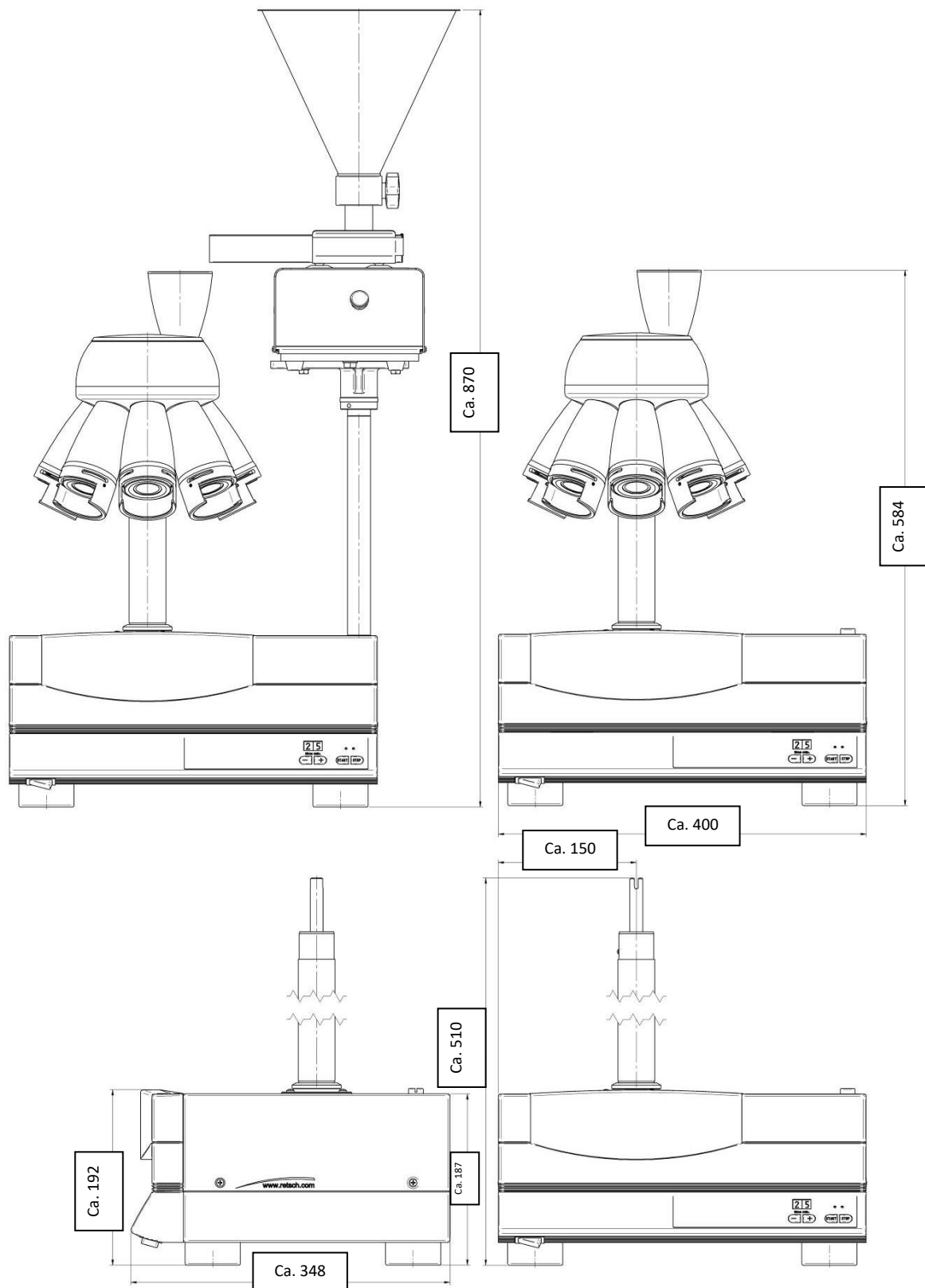

Fig. 2: Dimensions PT100 incl. sample dividers

Dimensions with vibratory feeder (without sample jars)

Height: 870 mm

Width: 400 mm

Depth: 348 mm

Dimension without vibratory feeder, dividing head and sample flasks

Height: 510 mm

Width: 572 mm

Depth: 348 mm

4.10 Required floor space

PT 100 incl. 10-outlet dividing head, quick-release sample outlet and 500-ml wide-mouth bottles:

Width: 480 mm

Depth: 420 mm

5 Operating the machine

5.1 Views of the Instrument

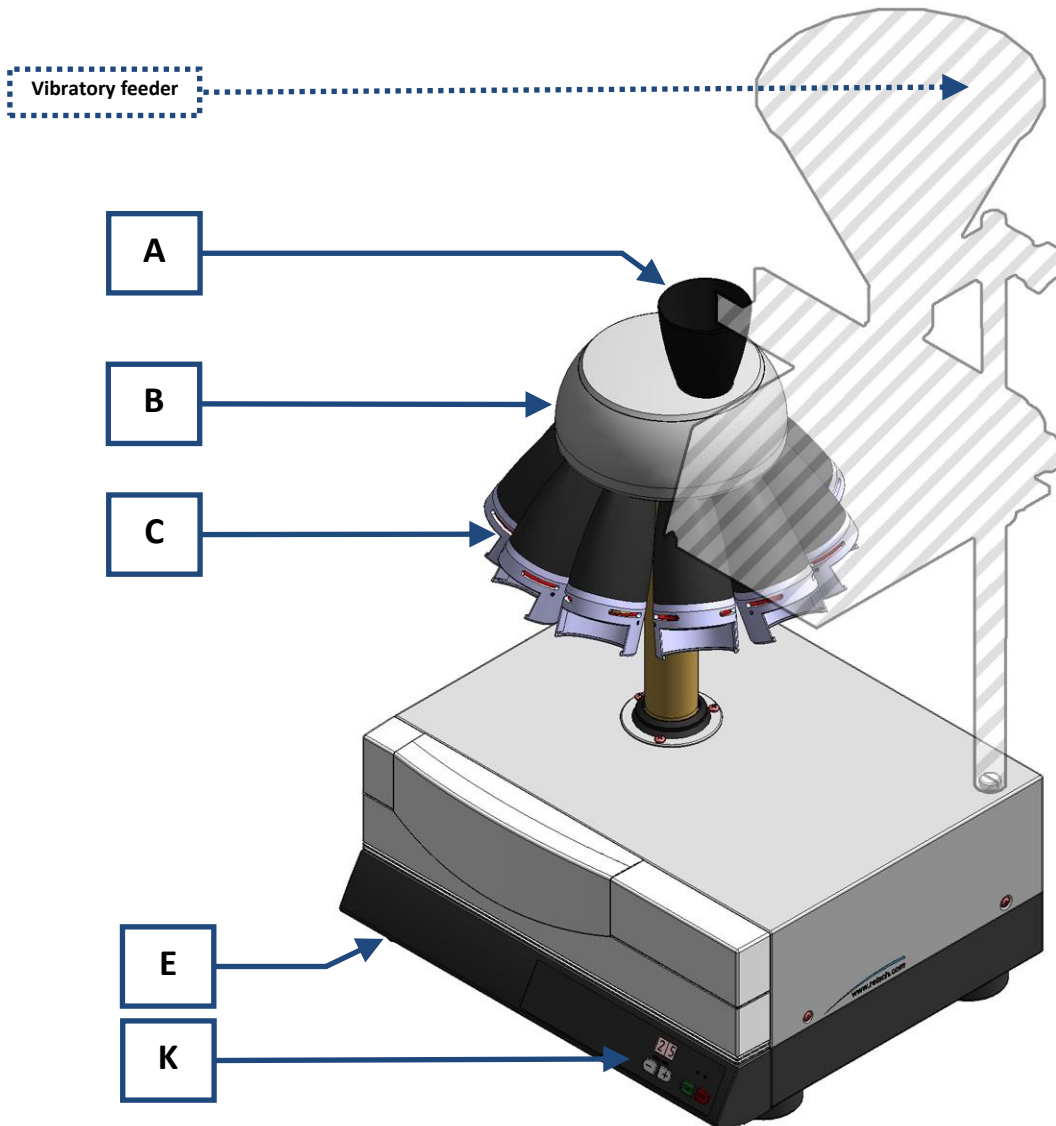

Fig. 2: General view of the device and the individual parts

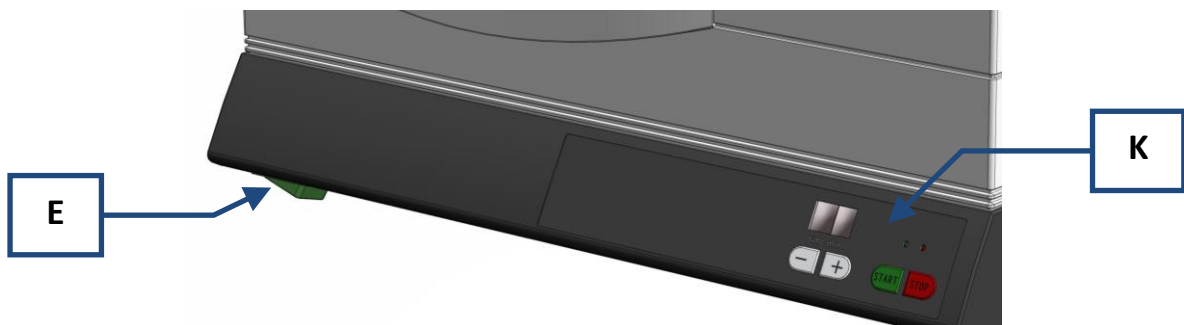

Fig. 3: View of the on/off switch and control panel

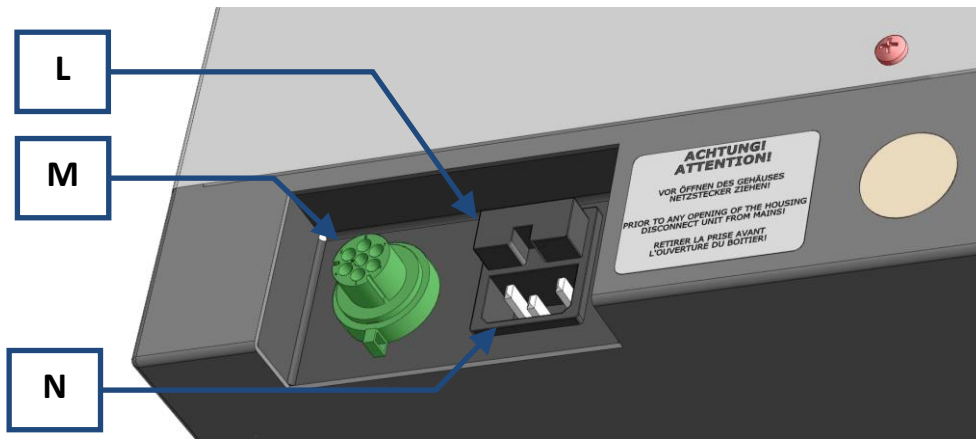

Fig. 4: Back of the device – power connection and interface

5.2 Overview table of the parts of the device

Element	Description	Function
A	Dividing head hopper	Accommodates a feed hopper, available as an accessory, or guides the sample material from the vibratory feeder into the tube dividers.
B	Dividing head	Divides the sample among the sample containers.
C	Adapter tube with quick-release sample outlet	Holds the sample vessels
E	Main switch	Switches the device on and off.
K	Control panel	START / STOP, time display, runtime setting
L	Fuse tray	Contains two glass fuses
M	Interface to the vibratory feeder	Links the connection cable to the vibratory feeder
N	Power socket	Connection for the mains power cable

5.3 Operating elements and displays

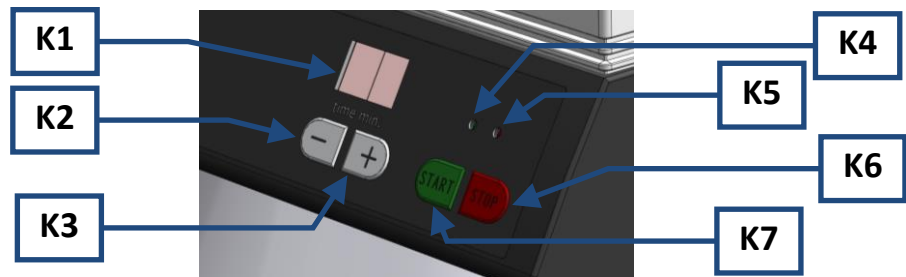

Fig. 5: Control panel

5.4 Overview Table of the Operating Elements and the Display

Element	Description	Function
K1	Display	Displays the set dividing time and the error messages
K2	- button	Reduces the dividing time
K3	+ button	Increases the dividing time
K4	Green LED	Display device switched on / running
K5	Red LED	Device stopped
K6	STOP button	Stopping the device/ pause
K7	START button	Starting the device

5.5 Mounting the dividing head/dg_bm "text_mod_1315215336450_0001">

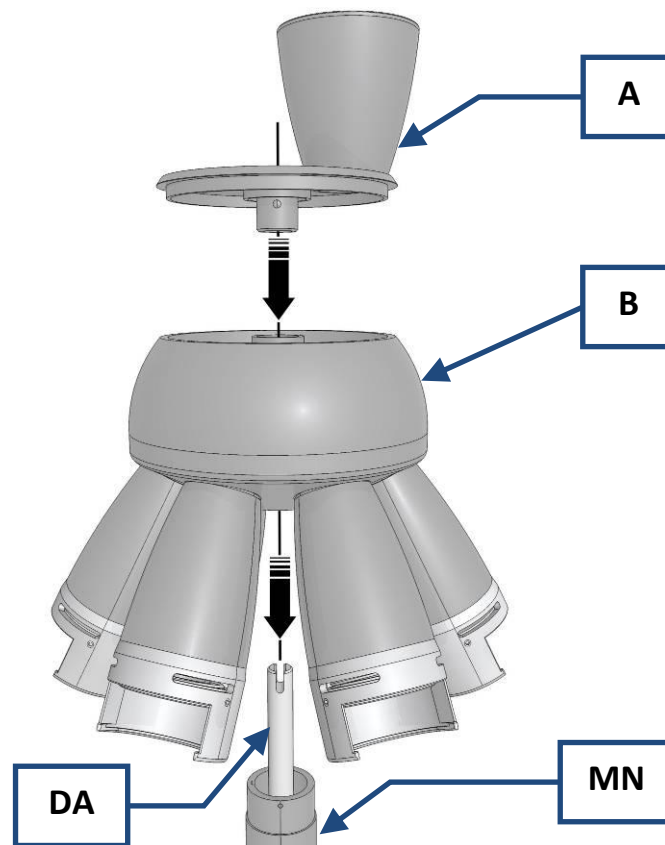

Fig. 6: Mounting the dividing head

- Put the dividing head (B) on the shaft (MN) as shown in the illustration.
- Put the dividing head hopper (A) onto the axle (DA).

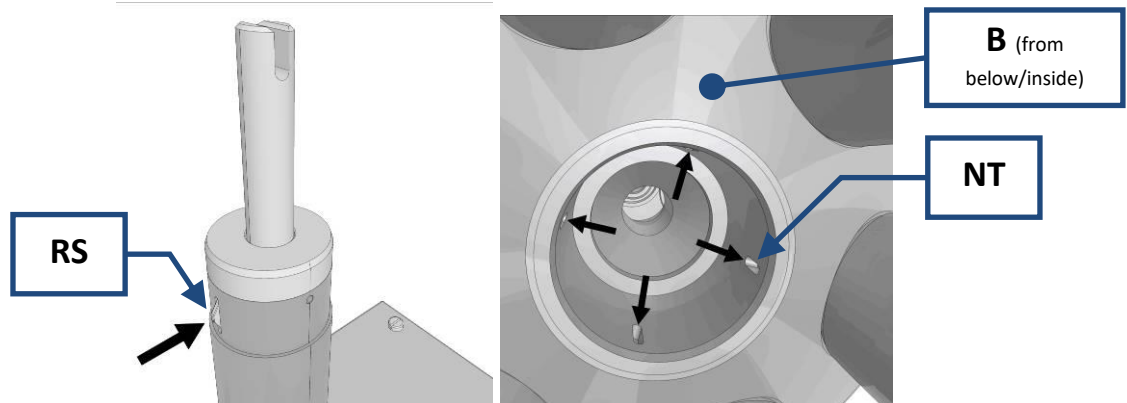

Fig. 7: Locking disk on the driver and dividing head viewed from below

Make sure that one of the four grooves (NT) engages with the locking disk (RS).

5.6 Inserting sample vessel

CAUTION

1.V0062

Injuries in the form of cuts and other personal injuries

Danger from glass splitters

- Injuries in the form of cuts can be caused by damaged sample flasks and glass splitters.
- **Replace damaged sample flasks**
- Do not touch glass splitters with your hands.

CAUTION

Danger of personal injury

Dangerous nature of the sample

- Depending on the dangerous nature of your sample, take the necessary measures to rule out any danger to persons.
- **Observe the safety guidelines and datasheets of your sample material.**



NOTICE

2.H0057

- It must be ensured that **all** tube dividers are fitted with sample containers. Otherwise, the sample will be scattered through the missing sample containers into the environment. (Loss of material)
- Make sure the sample containers are positioned correctly on the mountings. If the glass bottles are inserted incorrectly, they can be hurled out of the dividing head by centrifugal force.

3.

5.6.1 Inserting the sample container into the quick-release sample outlet

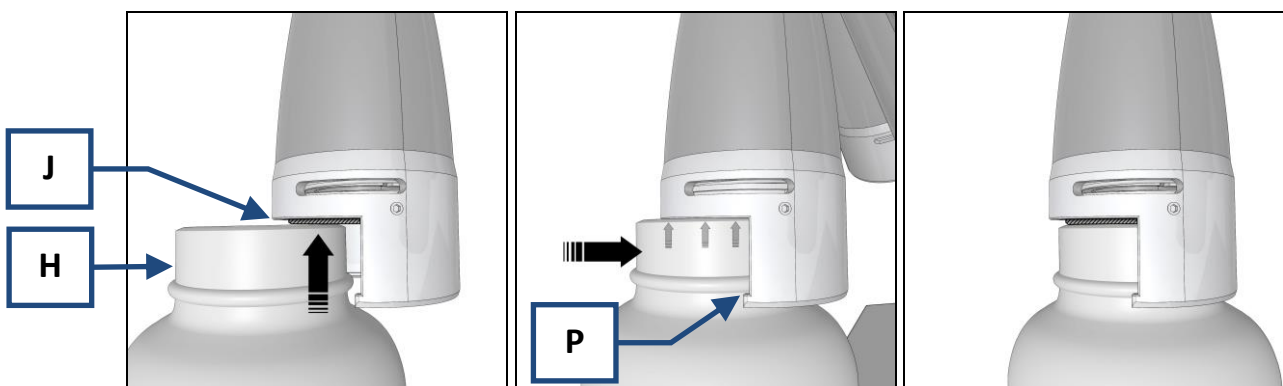

Fig. 4:

Fig. 5: Inserting the sample container (quick-release sample outlet)

- Position the sample container (**H**) in relation to the compression disk (**J** [shaded]).
- Press the compression disk (**J**) along with the sample container (**H**) upwards.

- Push the sample container backwards into the support (P) and lower it until it locks into place.

5.7 Switching On and Off

WARNING

Risk of a fatal electric shock

- An electric shock can cause injuries in the form of burns and cardiac arrhythmia, respiratory arrest or cardiac arrest.
- **Do not clean the blender under running water. Use only a cloth dampened with water.**
- **Disconnect the power supply plug before cleaning the blender.**

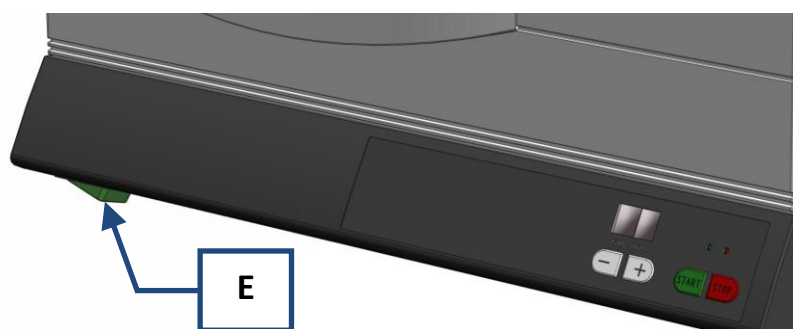

Fig. 8: On/off switch

There is an on-and-off switch (E) located on the left side of the device under the operating element.

- Press the switch (E) to turn the device on or off.

5.8 Starting, Interrupting, Stopping

5.8.1 Starting

- Press the (K7) START button.
- The green (K4) LED lights up over the (K7) START button.
- The preset dividing time can be seen in the (K1) display.
- The dividing head starts to rotate.
- The remaining dividing time minutes are shown in the display. (except in the **co** mode → Continuous operation)

5.8.2 Interrupting

- Press the (K6) STOP button.
- The dividing head is decelerated and the DR 100 (if one is used) switches off.
- The dividing time is interrupted and the (K5) LED lights up in red.
- The remaining dividing time appears in the display.

5.8.3 Stopping

- Press the (K6) STOP button twice.

- The device is put into readiness mode. (Standby)
- Press the **(K7)** START button to reactivate the device.

5.9 Process Run Duration

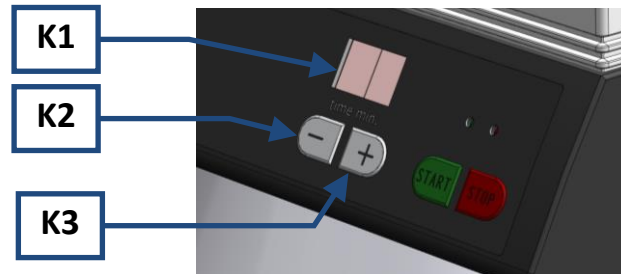

Fig. 1: Setting the processing time

5.9.1 Process run times

You can set the division process time by pressing the **+ button (K3)** or **- button (K2)**.

- Press the + button **(K3)** repeatedly until you reach the appropriate process run time.

You can select the following time intervals: (in minutes)

co (continually) – 1 – 3 – 5 – 10 – 20 – 30 – 40 – 50 – 60

5.9.2 Continuous run

- Press the + **(K3)** or **(K2)** button repeatedly until **co** appears in the display. During the dividing time, the speed is kept at a constant level within the set tolerance.

5.10 Attaching vibratory feeder

To prepare the vibratory feeder, you need the DR100 operating manual. For a precise sample division, it is recommendable to feed the sample uniformly through a vibratory feeder. The DR 100 vibratory feeder, which is available as an accessory, is suitable for that purpose. The connection between the device and the DR 100 is established by means of an interface cable, which is included in the DR 100 scope of supply. Both the device and the DR 100 require a mains power socket, each with the same phase position, providing the appropriate voltage and frequency (see type plate on the devices). Multi-distributor power sockets, to which both devices can be connected, are suitable for this purpose.

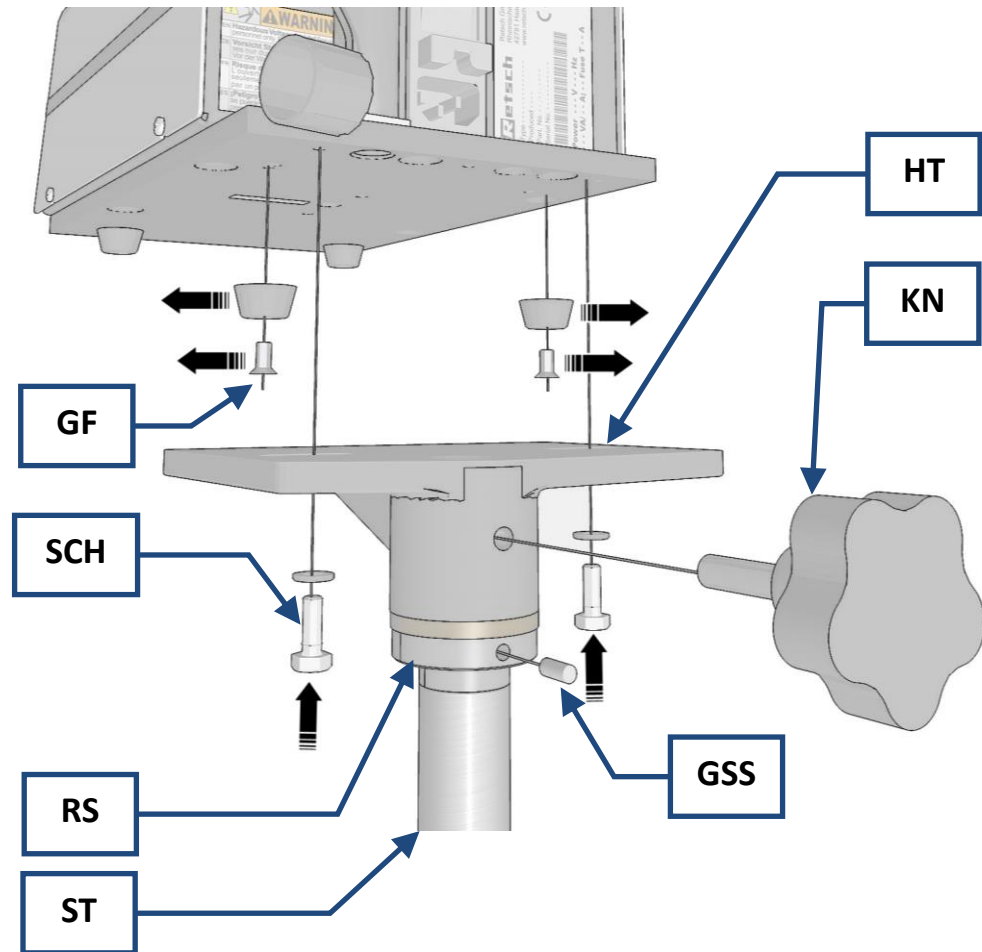

Fig. 2: Mounting the vibratory feeder

- The support (HT) is already completely pre-assembled with the stand rod (ST).
- Unscrew the two rubber feet (GF) at the back of the DR100.
- Loosen the hand screw (KN).
- Take the support (HT) off the stand rod (ST).
- Connect the DR 100 and the support (HT) by means of the hexagonal cap screws and washers (SCH).

Pay attention to the side position of the DR100 vibratory feeder. The position of the hopper opening varies depending on the dividing head being used.

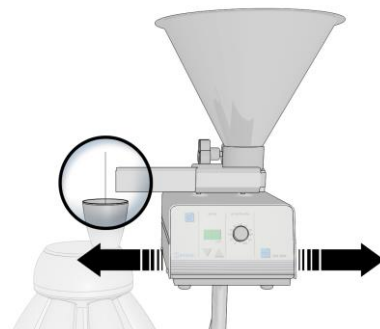

Fig. 3: Positioning the vibratory feeder

- Remove the plastic screw (**KS1**).
- Screw the stand rod (**ST**) onto the housing.

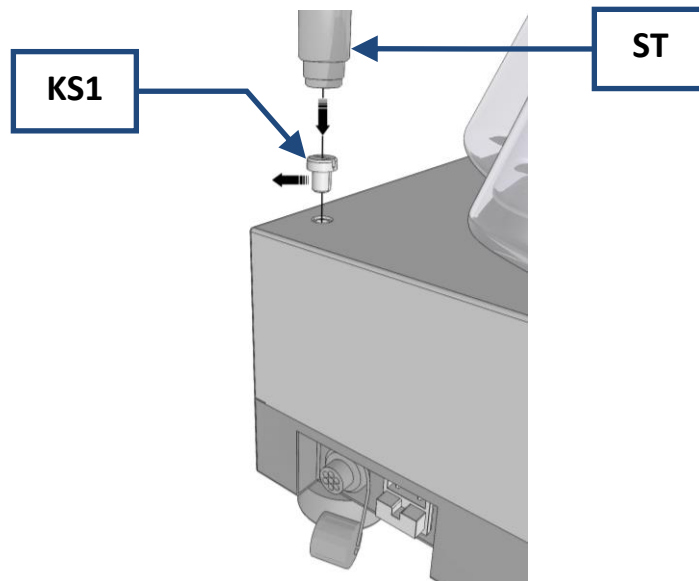

Fig. 4: Inserting the stand rod

- Mount the (**HT**) support.
- Adjust the swivel distance. To do so, loosen the threaded pin (**GS**) in the locking disk (**RS**).

Adjust the swivel distance so that the feeding chute is positioned in the centre over the feed hopper at the anti-clockwise limit stop and the support (**HT**) is swung out at the clockwise limit stop.

- Tighten the threaded pin (**GS**) in the locking disk (**RS**) again.
- Align the DR 100 chute over the PT 100 feed hopper.

The (**KN**) hand screw at the back of the support (**HT**) serves to lock the DR 100 in position.

When the (**KN**) hand screw is loosened, the DR100 can be swivelled 60°. The feed hopper with the dividing head is therefore accessible before and after the dividing process.

NOTICE

PT 100 and DR 100 must be suitable for the same electrical mains supply (see type plate).

Failure to comply with the ratings on the type plates on the PT 100 and DR 100 can cause damage to the electronic and mechanical components.

Please read the DR 100 operating instructions for information on the further operation of the DR 100.

5.11 Creating interface connection

- Before mounting the DR 100, read the DR 100 operating instructions.

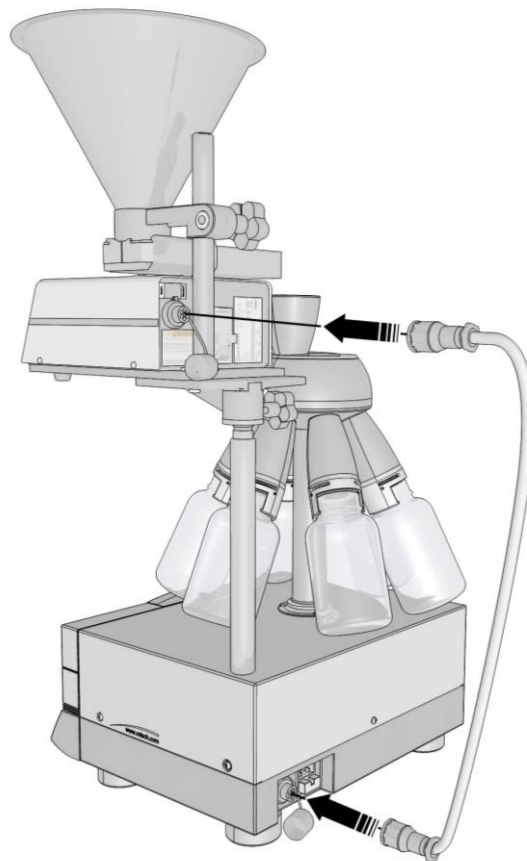

Fig. 5: Connection of the PT100 to the DR 100

Use the interface cable contained in the scope of supply for the retrofit kit to establish the connection between the DR 100 and the PT100.

- Insert the connection cable (**VK**) into the interface (**DF**) on the back of the DR 100.

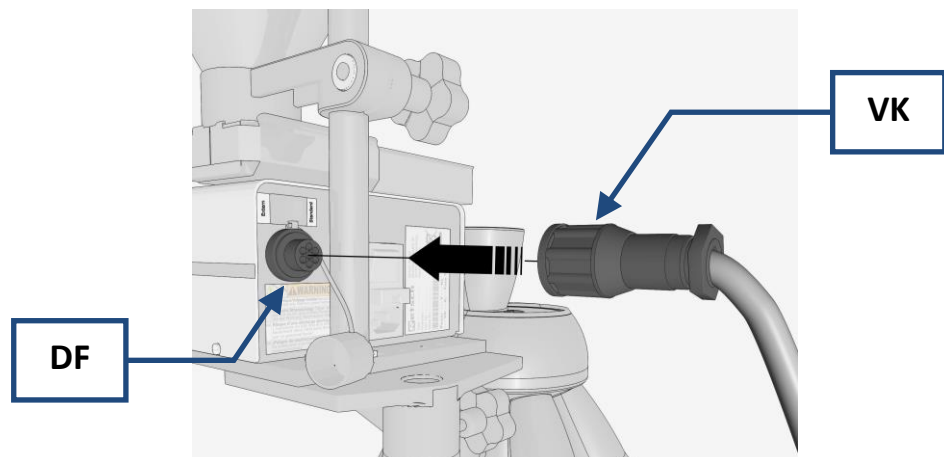

Fig. 6: Inserting the DR 100 connection cable

- Insert the connection cable (**VK**) into the interface (**PF**) at the back of the PT100.

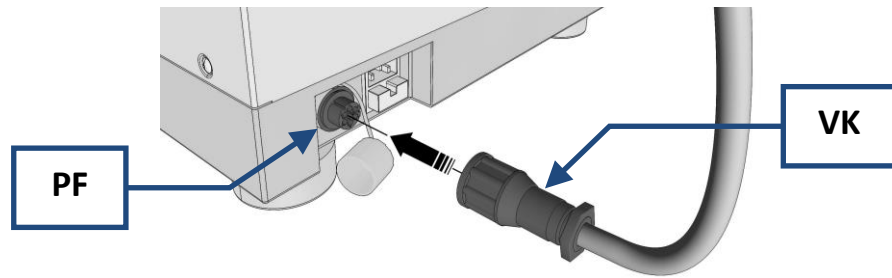

Fig. 7: Inserting the PT100 connection cable

5.12 Starting device and vibratory device simultaneously

- Put sample vessels onto all sample outlets on the device.

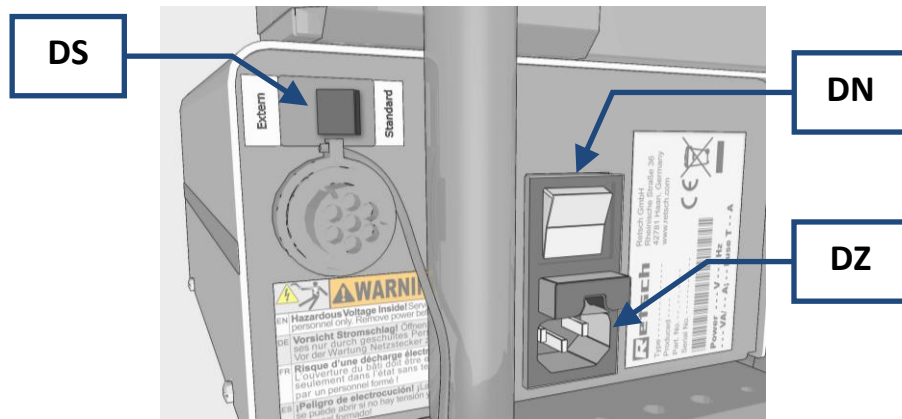

Fig. 4: Rear view of the DR100

NOTE

PT 100 and DR100 must be suitable for the same electrical mains supply, (see type plate).

Failure to comply with the ratings on the type plate on the PT 100 and DR100 can cause damage to electronic and mechanical components.

- Connect the DR100 to the mains power supply using the C13 panel-mounted male connector (inlet) **(DZ)**.
- Set the switch **(DS)** on the back of the DR100 to “Standard”.

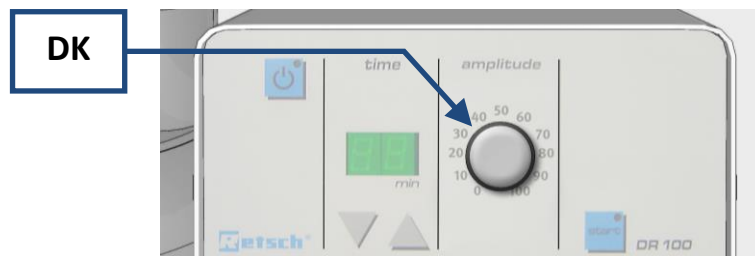

Fig. 5: Setting the DR100 feeding speed

- Set the feeding speed regulator **(DK)** on the DR100 to the required position (depending on the material to be divided).
- Fill the DR100 feed hopper.
- Adjust the slot width between the feed hopper outlet and the push-fit chute base (feed level).

The setting of the gap between the push-fit chute and the feed hopper depends on the maximum particle size of the feed material. It should be about 3 times as large as the max. particle size.

- Press the ON/OFF switch (**DN**) on the DR100 .
- Turn on the sample divider and start it.

The DR100 does not start until the sample divider has reached the nominal speed.

The DR100 switches off automatically when the nominal speed of the sample divider varies too much or drops. If this fluctuation lasts only for a short time (<5s), the DR100 switches on again once the nominal speed has been reached again and the feeding process is continued. As soon as you stop the sample divider, the DR100 stops too and the sample is not fed.

5.13 Replacing the machine fuses

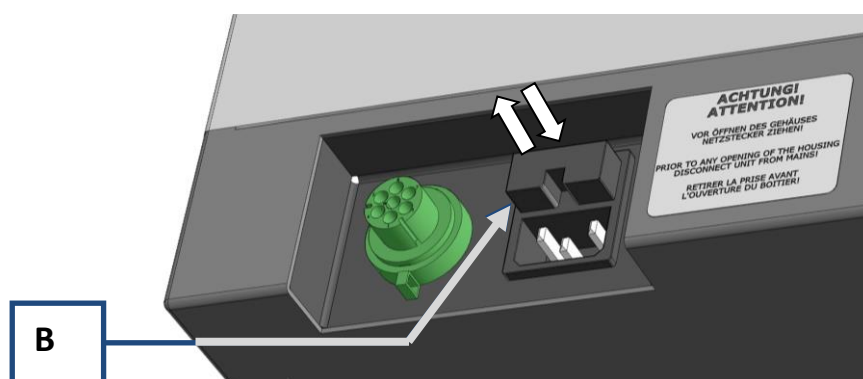

Fig. 8: Fuse holder

Required fuses:

2 glass fuses T 2A (5x20mm)

- Disconnect the mains plug.
- Pull out the fuse holder (**B**).
- Replace the fuses.
- Insert the fuse holder.

Only after-sales service may replace the fuses inside the device.

6 Cleaning and service

WARNING

Risk of a fatal electric shock

- An electric shock can cause injuries in the form of burns and cardiac arrhythmia, respiratory arrest or cardiac arrest.
- **Do not clean the blender under running water. Use only a cloth dampened with water.**
- **Disconnect the power supply plug before cleaning the blender.**

NOTICE

4.H0006

Defective components due to liquids

Penetration of liquids into the inside of the device

- Components are damaged and the function of the device is no longer ensured.
- **Clean the device under running water. Only use a moist cloth**

NOTICE

Damage to the machine through solvents

- Solvents may damage plastic parts and the paint finish.
- **It is not allowed to use solvents.**

The PT 100 laboratory sample divider is designed to allow all parts coming into contact with materials to be removed easily without tools. In detail these are:

- dividing head or
- Wide-mouth and DURAN® laboratory bottles
- Feed hopper and DR 100 push-fit chute

When these parts are removed from the device, they can be cleaned in a water bath, under running water and in a dishwasher.

7 Fault messages

Error code	Error	Measure
F1	Motor is not running or the rotation of the dividing head has been stopped manually	Press the STOP button; if the error persists, after-sales service must be consulted
F3	Speed too high or too low	Press the STOP button; if the error persists, after-sales service must be consulted
F5	Keypad defective	Service necessary

8 Disposal

Please observe the respective statutory requirements with respect to disposal.

Information on disposal of electrical and electronic machines in the European Community.

Within the European Community the disposal of electrically operated devices is regulated by national provisions that are based on the EU Directive 2002/96/EC on Waste Electrical and Electronic Equipment (WEEE).

Accordingly, all machines supplied after 13.08.2005 in the business-to-business area to which this product is classified, may no longer be disposed of with municipal or household waste. To document this they have the following label:

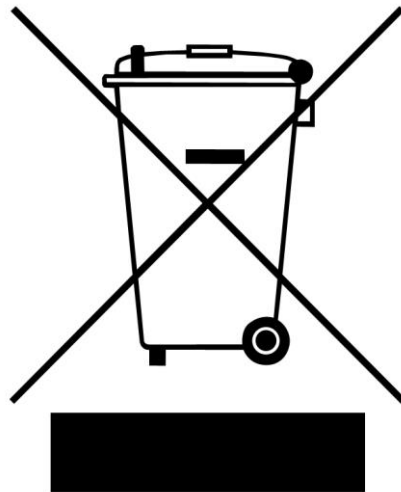

Fig. 5: Disposal label

Since the disposal regulations within the EU may differ from country to country we would request you to consult your supplier.

9 Index

4	
45635-31-01-KL3	12
5	
5,000cm ³	12
500cm ³	12
A	
Amperage	11
attaching vibratory feeder	22
B	
Back of the device	17
Bar code	11
Bulk material	12
C	
Capacity	11
CE marking	11
Changes	5
Cleaning and service	27
Conditions for the place of installation	10
Confirmation	9
Connection cable	11
continuously	12
Copyright	5
creating interface connection	24
D	
Degree of protection	12
Description	17, 18
Device designation	11
Dimensions	14
Dimensions and weight	13
DIN 45635-31-01-KL3	12
dispersed	12
Disposal	29
Disposal label	11
Disposal label	29
Division	12
Drive output	12
E	
Electrical connection	11
Emissions	12
Explanations of the safety warnings	6
External fuse	11
F	
F128	
F328	
F528	
Fault messages	28
feed size	13
free-flowing	12
Function	17, 18
Fuse strength	11
Fuse type	11
G	
General safety instructions	7
Grain size	12
Granulate	12

H	
Holding capacity, minimum, maximum.....	13
I	
Inserting sample vessel	19
Installation height.....	10
Installation of the machine.....	10
M	
Mains frequency.....	11
Manufacturer's address	11
Moderate or mild injury	6
Mounting the dividing head	18
N	
Noise characteristics.....	12
Noise data.....	12
Noise measurement	12
Notes on the Operating Manual.....	5
Number of fuses	11
O	
On/off switch.....	16
Operating elements and displays	18
Operating the machine.....	16
Overview Table of the Operating Elements and the Display	18
Overview table of the parts of the device.....	17
P	
Packaging.....	10
Part number.....	11
Powder.....	12
Power version.....	11
Process Run Duration	22
property damage	6
Q	
Quick-release sample outlet.....	20
R	
Rated power	13
Receptacle volume	13
Reduction.....	12
Regulations for the place of installation.....	11
Repairs	8
Replacing the machine fuses	27
Required floor space.....	15
Rotation speed.....	13
S	
Safety warnings.....	6
Serial number	11
serious injury	6
Service Address.....	8
Speed	13
starting device and vibratory device simultaneously.....	26
Starting, Interrupting, Stopping.....	21
Stepper motor	12
Switching On and Off.....	21
T	
Target group	7
Technical data.....	11
Temperature fluctuation and condensed water	10
Transport	10
Transport, scope of delivery, installation	10
Type plate	11

type plate description.....	10	View of the device	16
Type plate lettering	11	Views of the Instrument	16
U		Volume.....	12
uniformly	12	W	
Use.....	12	Workplace-related emission level	12
Use of the machine for the intended purpose...12		Y	
V		Year of production	11
View of the control panel.....	16		

SAMPLE DIVIDER

PT 100 | 40.535.xxxx

EU DECLARATION OF CONFORMITY

We, represented by the undersigned, hereby declare that the above device complies with the following directives and harmonised standards:

Machinery directive 2006/42/EC

Applied standards, in particular:

DIN EN ISO 12100:2011	Machine Safety - General Design Principles
DIN EN 61010-1	Safety Regulations for Electrical Measurement, Control, Regulation and Laboratory Devices

Electromagnetic compatibility 2014/30/EU

Applied standards, in particular:

EN 55011:2009	Industrial, scientific and medical equipment - Radio-frequency disturbance characteristics - Limits and methods of measurement
+A1:2010	
DIN EN 61326-1:2013	Electrical equipment for measurement, control and laboratory use - EMC requirements

Restriction of hazardous substances (RoHS) 2011/65/EU

Authorised person for compilation of the technical documentation:

Julia Kürten (Technical Documentation)

Furthermore, we declare that the relevant technical documentation for the above device has been prepared in accordance with Annex VII Part A of the Machinery Directive and we undertake to submit this documentation to the market surveillance authorities on request.

In the event of a modification of the device not agreed on by Retsch GmbH, as well as the use of non-approved spare parts or accessories, this declaration loses its validity.

Retsch GmbH



Dr. Kevin Schmitz, Head of Development

Haan, 04/2023





Copyright

® Copyright by
Retsch GmbH
Haan, Retsch-Allee 1-5
D-42781 Haan