

Isotemp™ Refrigerators and Refrigerator-Freezers

MODEL NO.

Flammable Materials Storage Refrigerator	05FREEFSA
Refrigerator	05LREEFSA
Refrigerator/Freezer	05LCEEFSA
Explosion Proof Refrigerator	05EREEFSA

IMPORTANT Read this instruction manual. Failure to follow the instructions in this manual can result in damage to the unit, injury to operating personnel, and poor equipment performance.

CAUTION All internal adjustments and maintenance must be performed by qualified service personnel.

Material in this manual is for informational purposes only. The contents and the product it describes are subject to change without notice. Fisher Scientific makes no representations or warranties with respect to this manual. In no event shall Fisher Scientific be held liable for any damages, direct or incidental, arising from or related to the use of this manual.

© 2018 Fisher Scientific Inc. All rights reserved.

Contents

Introduction	1
Alert Signals	1
Installation.....	2
Shipping Carton	2
Location	2
Electrical	2
Be Advised.....	2
Operation.....	4
Environmental Operating Conditions.....	4
Child Entrapment Warning.....	4
Start-Up Procedure	4
Restart Procedure	4
Manual Defrost Procedure.....	4
How to Save Energy.....	5
Safety Tips	5
Reversing the Front Door (Model 05LREEFSA)	5
Laboratory Units	6
Flammable Materials Storage Units	8
Overview	8
Explosion-Proof Units	10
Overview	10
Options.....	12
Optional Dolly.....	12
Installation Instructions	12

Maintenance	13
Be Advised.....	13
Cleaning of Units	13
Troubleshooting	14
Replacement Parts	15
Warranty	16

Introduction

Alert Signals



WARNING: Warnings alert you to a possibility of personal injury.



CAUTION: Cautions alert you to a possibility of damage to the equipment.



Note: Notes alert you to pertinent facts and conditions.



Shock Hazard: Potential for electrical shock or equipment damage exists if precautions are not followed.



DANGER: RISK OF CHILD ENTRAPMENT. BEFORE YOU THROW AWAY YOUR OLD REFRIGERATOR OR FREEZER:

- TAKE OFF DOORS
- LEAVE THE SHELVES IN PLACE SO THAT CHILDREN MAY NOT EASILY CLIMB INSIDE.



CAUTION: If the equipment is used in a manner not specified by the manufacturer, the protection provided by the equipment may be impaired.

The Fisher Scientific team is your laboratory partner. Meeting all the needs of today's laboratories, whether industrial, educational or government, large or small, is our sole objective.

Our 3,000 employees and 1,200 suppliers build on a long and proud tradition of quality performance to bring our customers an unmatched line of more than 130,000 products—plus the highest level of customer service, expert technical assistance, and fast, accurate delivery.

We are the largest distributor for most of the major manufacturers whom we represent. We also manufacture nearly 25% of the items we sell. With Fisher Scientific, our team is your team. You'll find our customer service representatives the most experienced and highly trained in the scientific industry, and they are quickly available to you via

our toll-free hotline: 1-800-438-4851. They'll assist you promptly, and in an error-free manner, by providing up-to-the-minute information on products, pricing, specifications, and delivery and return procedures. They'll arrange to have your order shipped from one of our many Customer Service Centers or additional warehousing facilities located coast-to-coast.

For toll-free technical assistance call: 1-800-438-4851, A Fisher Scientific Account Representative will visit your laboratory when your orders are too complex to resolve over the telephone. They'll listen carefully to your needs and help you decide on the combination of products and services that best fulfill your requirements. They can provide you with the details on quotations, technical information, product availability and ordering.

THE FISHER SCIENTIFIC QUALITY STATEMENT: "Every one of us on the Fisher Scientific team is committed to satisfying the needs of our customers by providing products and services that meet or exceed their requirements and expectations. We place top priority on quality, and we foster this through a continuing process of improvements, in which employee contributions play a vital role."

Installation

Shipping Carton

This should be inspected upon delivery. When received, carefully examine for any shipping damage before unpacking. If damage is discovered, the delivering carrier should both specify and sign for the damage on your copy of the delivery receipt.

Open the carton carefully making certain that all parts are accounted for before packaging materials are discarded. After unpacking, if damage is found, promptly report it to the carrier and request a damage inspection promptly.

IMPORTANT: Failure to request an inspection of damage within a few days after receipt of shipment absolves the carrier from any liability for damage. You must call for a damage inspection promptly.

Location

Locate your unit in the most convenient place and near a grounded electric outlet. If units are placed on a counter-top, the front should be 3" or more back from the edge to avoid accidental tipping of the unit.

If possible, locate your unit out of direct sunlight and away from heat sources such as a radiator, stove or heat duct.



CAUTION: DO NOT REMOVE, under any circumstance, the grounding prongs from the 3-prong power cord supplied with all units. No cord/plug is supplied with Explosion-Proof units. Contact a qualified electrician to hard-wire unit.

Electrical

With the exception of Explosion-Proof models, all units must be connected to a grounded outlet matching the nameplate and/or the information furnished in this manual.

If you are not sure about the outlet, you should contact a qualified electrician for assistance.

The unit should always be connected to its own individual outlet.



CAUTION: DO NOT USE electrical extension cords that may result in voltage loss and possible hazardous operation.

Explosion-Proof models do not come supplied with a cord and plug. Units must be hard-wired by a qualified electrician.

Be Advised



DANGER: RISK OF CHILD ENTRAPMENT. BEFORE YOU THROW AWAY YOUR OLD REFRIGERATOR OR FREEZER:

- TAKE OFF DOORS
- LEAVE THE SHELVES IN PLACE SO THAT CHILDREN MAY NOT EASILY CLIMB INSIDE



DANGER: UNLESS UNIT IS SPECIFICALLY DESIGNED FOR COMBUSTIBLE OR FLAMMABLE ATMOSPHERES DO NOT USE IN THE PRESENCE OF FLAMMABLE OR COMBUSTIBLE MATERIALS OR EXPLOSIVE GASES. DO NOT USE IN THE PRESENCE OF PRESSURIZED OR SEALED CONTAINERS— FIRE OR EXPLOSION MAY RESULT CAUSING DEATH.



WARNING: BEFORE CONNECTING THE FINAL POWER SUPPLY, CHECK THE ELECTRICAL CHARACTERISTICS OF THE UNIT NAMEPLATE TO SEE THAT IT IS IN AGREEMENT WITH THE POWER SUPPLIED. IN ADDITION, POWER SHOULD BE WIRED TO THE UNIT ACCORDING TO THE ELECTRICAL SCHEMATIC AND ALL APPLICABLE CODES. ONLY QUALIFIED ELECTRICIANS SHOULD WORK ON THE ELECTRICAL PORTION OF ANY UNIT INSTALLATION.



CAUTION: SOLUTIONS USED TO CLEAN COILS OR NEUTRALIZE BACTERIA GROWTH MUST NOT BE CORROSIVE TO METALS (ENAMEL-COATED STEEL) AND MATERIALS USED IN THE MAINTENANCE OF THIS EQUIPMENT— DAMAGE CAN RESULT. USE A SOFT CLOTH AND WARM WATER TO CLEAN.

How to Seal Killark™ Box Conduit with Fiber and Sealing Compound to Help Protect Against Explosions (Explosion-Proof Units Only):

The purpose of the procedure that follows is to build fiber rope dams on the left and right hubs of the horizontal conduit. The fiber rope dams will surround conduit wiring that is housed inside the horizontal conduit.

When both the left and right fiber rope dams have been pressed into place, sealing compound is poured between the two and forms into an airtight plug.

All of this is done in order to prevent the very real threat of gas entering the Killark box and a resulting serious explosion. After the unit wires have been pulled through the horizontal conduit the following procedure is required:

- Turn power off at the circuit breaker before proceeding.
- Place a small amount of sealing compound granules, enclosed, into a clean mixing vessel. Add small amounts of water while stirring until a thick paste is formed, then carefully continue adding smaller amounts of water until a thick gravy consistency is achieved—NOT WATERY. Discard any material that becomes too stiff to use. Never attempt to restore workability by stirring in more water.
- Locate silver Killark box, back/top-center of unit.
- Unscrew conduit domed-cover.

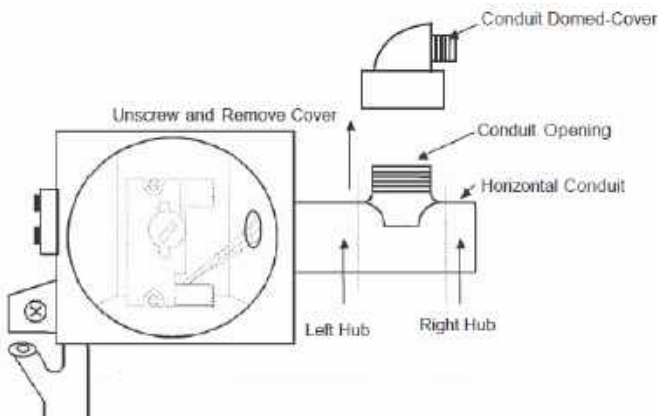

Figure 1. Sealing the Killark Box

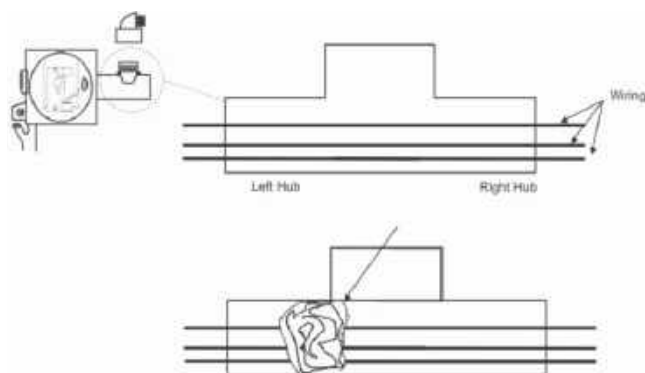
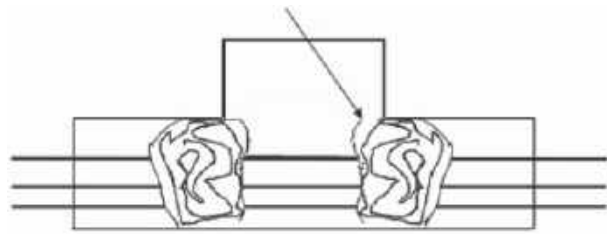
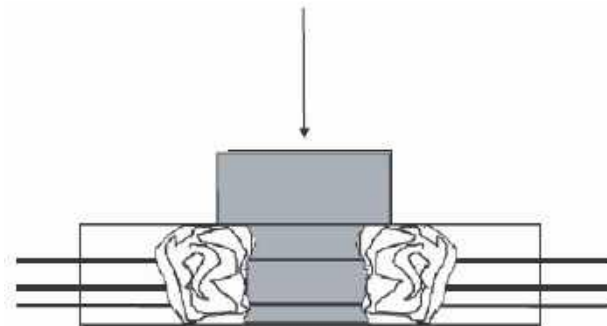

Figure 2. Horizontal Conduit, Cutaway

- Insert fiber rope material down into horizontal conduit opening. Pressing down firmly, work the material into the left hub and—most importantly—being sure the material **COMPLETELY SURROUNDS THE WIRING**, from the top to the bottom, completely blocking this end of the horizontal conduit.



- Insert fiber rope material down into horizontal conduit opening. Pressing down firmly, work the material into the right hub and—most importantly—being sure the material **COMPLETELY SURROUNDS THE WIRING**, from the top to the bottom, completely blocking this end of the horizontal conduit.



- Pour sealing compound down in between the two fiber rope dams filling the remaining space. Pour slowly, being careful not to trap air bubbles. Immediately wipe off any spilled sealing compound.
- Screw conduit domed-cover back onto conduit opening.

Note: INITIAL SETUP OF SEALING COMPOUND WILL OCCUR IN APPROXIMATELY 30 MINUTES HOWEVER, THE SEALING COMPOUND REQUIRES A **MINIMUM OF 8 HOURS ABOVE 32°F** TO DEVELOP SUFFICIENT STRENGTH TO WITHSTAND EXPLOSIONS.

Operation

Environmental Operating Conditions

POLLUTION DEGREE*:	2
INSTALLATION CATEGORY*:	II
ALTITUDE:	2000 Meters MSL (Mean Sea Level)
HUMIDITY:	80% maximum, non-condensing
ELECTRICAL SUPPLY:	120 V AC
VOLTAGE TOLERANCE:	±10% of normal rated line
TEMPERATURE:	15°C to 40°C
PRODUCT USAGE:	This product is intended for use indoors only

*Refer to IEC 664-1

Child Entrapment Warning



DANGER: RISK OF CHILD ENTRAPMENT!

Before you discard your old refrigerator or freezer:

- Remove door(s),
- Leave the shelves in place so that children may not easily climb inside.

Start-Up Procedure

Rotate the control knob clockwise to lower the temperature and counterclockwise raise it.

To check chamber temperature, place a dial thermometer on a shelf in the center of the chamber. Initially, rotate the temperature control knob to an arbitrary setting. Allow approximately 2 hours for the temperature to initially stabilize. Check the temperature and compare with the dial setting.

Adjust dial further to reach the desired operating temperature. After chamber initially stabilizes, allow 1/2 hour to 1 hour for the chamber temperature to stabilize after subsequent temperature adjustments.

Because the markings on the dial do not indicate specific temperatures, use them AS REFERENCE POINTS ONLY for any future setting of the temperature.

If the room thermostat is turned below 60°F at night, consider setting the temperature control one step colder. It should be left at this setting for the nighttime period; return temperature control to original setting when the room thermostat is returned to its normal setting.

Restart Procedure

If unit is unplugged or turned off, allow 3 minutes before restarting or plugging it back in.

Manual Defrost Procedure

(Where Applicable)

Do not use any sharp instrument, blade or scraper to remove ice and frost on refrigerator surfaces because of the very real danger of puncturing the cooling coil.

Do not use any electrical device to defrost the unit.

When frost accumulates to 1/4" or more, the operating efficiency of the unit will be affected. Use the following procedure to defrost manually:

- Rotate the temperature control knob to the OFF setting.
- Disconnect the power cord from its outlet.
- Remove contents of unit. If practical, wrap contents in paper and then in a heavy blanket to maintain temperature of items, especially those removed from a freezer. Wear protective gloves to prevent frostbite when handling cold items.
- Open door and allow free circulation of ambient air.
- To speed the process, place pan of warm water inside the chamber.
- Wipe out the interior.
- Replace contents.
- Reconnect power cord to outlet and set temperature control to desired operating temperature.



- Do not use a power cord that shows cracks or abrasions. Have a qualified electrician repair or replace damaged cords immediately.

Reversing the Front Door (Model 05LREEFSA)

- Remove bolts and plugs using a screwdriver.
- Unscrew the bolts connecting the upper hinges to the upper platform. Remove the upper platform by first pulling it forward and then lifting it upward.
- Remove the door by unscrewing the bolts in the upper hinges.
- Remove the buffer by unscrewing the bolts on both of its sides.
- Break off the part behind the buffer through which the lower hinges pass using a knife or your hands.
- Remove the lower hinge and mount it on the other side tightening its bolts.
- Remove the hole-plugs of the door handle with a knife.
- Fit the hole-plugs of the door handle to the other side.
- Fit the buffer to its place.
- Mount the door to its place.
- Fit the upper hinges into their places. Do not tighten the bolts, but leave them loose.
- Adjust the vertical and parallel position of the door by eyesight then tighten the bolts of the upper hinges.
- Fit the upper platform into its place.
- Fit the bolts connecting the upper hinges and the upper platform, but do not tighten them.
- Adjust the upper platform until it is level then tighten the bolts in operations.
- Fit the plugs of the upper platform.

How to Save Energy

- Be sure to follow location suggestions as mentioned in the previous INSTALLATION section.
- Wipe moisture from glassware or other materials before placing them in a unit.
- Don't overcrowd the unit. Too many items can increase electrical energy demand in order to keep everything cool.
- Close the door as soon as possible in hot, humid weather.
- Make certain that the door is closed tightly.
- As soon as frost has accumulated to 1/4", defrost.
- Keep containers covered, when possible, to reduce moisture buildup.
- Set operating temperature no colder than necessary for the items being refrigerated.

Safety Tips



- After a unit is in operation, do not touch the cold surfaces, particularly when hands are damp. Skin may adhere to the extremely cold surfaces.



- Never disconnect your unit by pulling on the power cord. Always grip the plug securely and pull straight out from the outlet.

Laboratory Units

MODEL 05LREEFSA

Features:

- 5.5 cubic ft. undercounter refrigerator.
- Manual defrost.
- Adjustable hydraulic thermostat control.
- Three adjustable wire shelves.
- Key lock.
- UL listed.



05LREEFSA Note: THESE UNITS ARE DESIGNED FOR FREE STANDING INSTALLATION ONLY. THEY MAY BE INSTALLED UNDER A COUNTER ONLY IF SUFFICIENT SPACE FOR AIRFLOW IS PROVIDED. 1" ON THE SIDES, TOP AND REAR ARE RECOMMENDED.

Model	Refrigerator Chamber Dimensions H x W x D inches (cm)	Total Vol. Cu. Ft.	Exterior Dimensions H x W x D inches (cm)
05LREEFSA	27.8" x 20" x 17.5" (70 x 51 x 44 cm)	5.5	33.5" x 23.63" x 23.5" (85 x 60 x 60 cm)

Model	Electrical Characteristics Volts/Hz, Watts, Amps	Refrig. Temp. Range °C (°F)	Net Wt. Lbs. (kg)	Ship Wt. Lbs. (kg)
05LREEFSA	115/60, 115, 1	1° to 12° (34° to 54°)	100 (46)	120 (55)

Note: Amps listed are at normal run mode, starting amps may be higher.

MODEL 05LCEEFSA

Features:

- 5.6 cubic ft. undercounter refrigerator/freezer.
- Adjustable thermostatic control.
- Three Glass shelves, three door shelves.
- ABS plastic interior with enameled steel exterior.
- Manual defrost.
- UL listed.



05LCEEFSA Note: THESE UNITS ARE DESIGNED FOR FREE STANDING INSTALLATION ONLY. THEY MAY BE INSTALLED UNDER A COUNTER ONLY IF SUFFICIENT SPACE FOR AIRFLOW IS PROVIDED. 1" ON THE SIDES, TOP AND REAR ARE RECOMMENDED.

Model	Refrigerator Chamber Dimensions H x W x D inches (cm)	Freezer Chamber Dimensions H x W x D inches (cm)	Total Vol. Cu. Ft.	Exterior Dimensions H x W x D inches (cm)
05LCEEFSA	19.5" x 20.5" x 17" (50 x 52 x 43 cm)	5" x 19" x 11.5" (13 x 48 x 29 cm)	5.6	33.5" x 23.63" x 23.5" (85 x 60 x 60 cm)

Model	Electrical Characteristics Volts/Hz, Watts, Amps	Refrig. Temp. Range °C (°F)	Freezer Temp. Range °C (°F)	Net Wt. Lbs. (kg)	Ship Wt. Lbs. (kg)
05LCEEFS	115/60, 150, 1.3	1° to 12° (34° to 54°)	-12° to -20° (10.4° to -4°)	100 (46)	120 (55)

Note: Amps listed are at normal run mode, starting amps may be higher.

Flammable Materials Storage Units

Overview

Conventional refrigerators and freezers are not suitable for storing flammable materials. Such units have components in their electrical and refrigeration systems that can trigger explosions of flammable air-vapor mixtures inside the unit.

Flammable Materials Storage (FMS) refrigerators/freezers are designed for use in locations, which are not classified by the Authority Having Jurisdiction (AHJ) as hazardous. Under normal operating conditions the build up or presence of flammable vapors will not occur in the environment external to the unit. (Commonly known as “Ordinary Locations”).

FMS units are NOT designed for use in Class I, Groups C and D environments, which require an Explosion-Proof Refrigerator/Freezer.

FMS units are designed and evaluated by Underwriters Laboratories (UL) to meet the requirements of the National Fire Protection Association Standards Nos. 45, 70 and 99. These units have no internal electrical components that could trigger an explosion or fire of hazardous materials inside the unit.

These units are ideal for storing cyclopropane, ethyl ether, ethylene, acetone, alcohol, benzene, butane, gasoline, hexane, lacquer solvent vapors, naphtha, natural gas or propane along with many other potentially hazardous materials.

All models have heavy-gauge, rigid, steel construction with a durable enamel finish. Interiors have epoxy enamel or ABS plastic construction. Each unit is insulated throughout for energy-efficient operation.

MODEL 05FREEFSA

Features:

- 5.5 cubic ft. undercounter refrigerator.
- Hydraulic thermostat.
- Three adjustable wire shelves.
- Aluminum evaporator coil.
- Manual defrost.
- Key locking door.
- UL listed.



05FREEFSA Note: THIS UNIT IS DESIGNED FOR FREE STANDING, RECESSED OR UNDER THE COUNTER INSTALLATION. IT IS SUGGESTED THE USER HAVE EASY ACCESS TO THE KEY LOCK.

ALLOW FOR 4 INCHES OF ADDITIONAL SPACE AT THE REAR OF FLAMMABLE MATERIAL STORAGE UNITS TO ACCOMMODATE THE THERMOSTAT HOUSING.

Model	Refrigerator Chamber Dimensions H x W x D inches (cm)	Total Vol. Cu. Ft.	Exterior Dimensions H x W x D inches (cm)
05FREEFSA	27.75" x 20" x 17.5" (71 x 51 x 45 cm)	5.5	33.5" x 23.63" x 28.1" (85 x 60 x 71 cm)

Model	Electrical Characteristics Volts/Hz, Watts, Amps	Refrig. Temp. Range °C (°F)	Net Wt. Lbs. (kg)	Ship Wt. Lbs. (kg)
05FREEFSA	115/60, 115, 1.0	1° to 12° (34° to 54°)	100 (46)	120 (55)

Note: Amps listed are at normal run mode, starting amps may be higher.

Explosion-Proof Units

Overview

Conventional refrigerators and freezers are not suitable for storing flammable materials. Such units have components in their electrical and refrigeration systems that can trigger explosions of flammable air-vapor mixtures inside the unit and/or in the immediate surrounding area.

The Authority having Jurisdiction (AHJ) determines if work areas are designated as a hazardous location with respect to the presence of flammable gases or vapors. Such locations are defined in (National Fire Protection Agency) NFPA 70 Articles 500-501 and OSHA 29 CFR1910.307. Some of these classified areas are expected to experience concentrations of flammable gases and/or vapors at or above their lower flammability limits for extended periods of time. The construction of our explosion-proof units has been evaluated by Underwriters Laboratories (UL) and are suitable for use in classified areas requiring Class I, Groups C and D* protected equipment. The electrical components such as thermostats, wiring, splices, relays and compressor motors on explosion-proof units are safely housed within explosion-proof enclosures and conduit. Compressor surface temperatures have been evaluated and determined to remain below the flash point of materials found in Class I, Groups C and D. All models have heavy-gauge, rigid, steel construction with a durable enamel finish. Interiors have epoxy enamel or ABS plastic construction. Each unit is insulated throughout for energy-efficient operation.

These units are ideal for storing cyclopropane, ethyl ether, ethylene, acetone, alcohol, benzene, butane, gasoline, hexane, lacquer solvent vapors, naphtha, natural gas or propane along with many other potentially hazardous materials.

*The notation Class 1, Groups C and D is an accepted abbreviation for Class I, Div 1, Groups C and D.

MODEL 05EREEFSA

Features:

- 5.5 cubic ft. undercounter refrigerator.
- Hydraulic thermostat.
- Three adjustable wire shelves.
- Manual defrost.
- UL listed.



05EREEFSA Note: ALLOW 5 INCHES OF ADDITIONAL REAR SPACE FOR EXPLOSION-PROOF UNITS TO ACCOMMODATE THE THERMOSTAT HOUSING.

Model	Refrigerator Chamber Dimensions H x W x D inches (cm)	Total Vol. Cu. Ft.	Exterior Dimensions H x W x D inches (cm)
05EREEFSA	27.75" x 20" x 17.5" (71 x 51 x 45 cm)	5.5	33.5" x 23.63" x 28.1" (85 x 60 x 71 cm)

Model	Electrical Characteristics Volts/Hz, Watts, Amps	Refrig. Temp. Range °C (°F)	Net Wt. Lbs. (kg)	Ship Wt. Lbs. (kg)
05EREEFSA	115/60, 115, 1	1° to 12° (34° to 54°)	100 (46)	120 (55)

Note: Amps listed are at normal run mode, starting amps may be higher.

Options

Optional Dolly

- 2,000 lb. capacity
- Simple wing nut adjustment shortens or lengthens the rollers to fit refrigerators/freezers of various sizes
- 18" to 28" adjustable length
- 32 ea. 1-1/4" nylon rollers
- Non-skid foam rubber corner pads hold unit firmly in place
- 3/32" thick aluminum frame construction, 3" wide x 1-1/2" high

Installation Instructions

Note: Not recommended for use on cushioned vinyl flooring.

1. Move refrigerator/freezer away from wall.
2. Prepare roller by loosening wing nut on the inside of the roller bar. Adjust the roller to the depth desired and firmly tighten the wing nut.
3. Lift one side of the refrigerator/freezer and place it on the roller. Make sure "support points" under the unit are centered on each rubber pad.
4. Repeat procedure for other side of appliance.

Maintenance

Be Advised

Make no attempt to service or repair a Fisher Scientific product under warranty before consulting Fisher Scientific. After the warranty period, such consultation is still advised, especially when the repair may be technically sophisticated or difficult.

If assistance, please call Fisher Scientific Customer Relations Department: 1-800-438-4851.

No merchandise, however, should be returned directly to Fisher Scientific without prior written approval from Fisher Scientific.

Cleaning of Units

- Disconnect power cord from its outlet.
- Set the temperature control to the OFF position.
- The unit designs permit easy and rapid cleaning and should not take more than a few minutes. Remember to wear protective gloves to prevent frost bite, especially when removing items from freezer units.
- Do not use abrasive scouring powders, waxes, solvents, furniture polish, undiluted detergents or cleansers containing petroleum products on the surfaces of units.

Interior/Exterior and Door Gaskets

A solution of mild soap and water can be used for cleaning the interior, exterior and door gaskets with a soft, clean cloth. Rinse with clean water and dry thoroughly before reconnecting and turning on the unit.

Condenser

With forced-fan vented units, remove the screws that mount the grill to the unit. Pull temperature control knobs straight out. This will expose condenser for cleaning.

Troubleshooting

In the event that your unit is not operating properly, check the following before calling for service assistance. This may save you the cost of unnecessary service calls.

Symptom	Possible cause of Problem
Unit not operating.	<p>Make certain that the unit is connected to a grounded outlet.</p> <p>Make certain that temperature control knob is ON.</p> <p>Check that circuit breaker is not tripped or fuse is not blown.</p>
Unit runs continuously.	<p>Make certain that there is no heavy frost accumulation. If there is, defrost unit.</p> <p>Look at condenser to see if there is a layer of dust or lint. Clean if required with a dry brush or vacuum.</p> <p>A leak around the door gasket will allow cold air to escape. This causes unit to work harder than necessary to maintain cold temperatures. Re-seat or replace gasket if worn.</p> <p>If you have temperature set too cold, this may cause unit to run continuously. Check optimum running temperature.</p> <p>Is the ambient air over 43°C (109°F), or the units located close to heat sources? If possible, move to a different location.</p> <p>An unusually high frequency of door openings and closings can increase operating load. Unit will stabilize as these are decreased.</p>
Noise problems.	<p>This can be caused by contents of unit being set too close and rattling against each other.</p> <p>Rearrange contents as needed. Hissing or gurgling noise is caused by refrigerating fluid circulating and is normal.</p> <p>Noise can result if unit is not level on floor. Check with level.</p> <p>Fan noise: normal airflow can cause this, not a problem.</p>

Replacement Parts

To obtain replacement parts information and pricing, please call the Fisher Scientific Customer Relations Department at 1-800-438-4851 and have the unit's model, serial and code numbers available. This information is located on data plates on the rear of the unit.

Warranty

Laboratory instruments and equipment manufactured by Fisher Scientific Company L.L.C. – Laboratory Equipment Division (hereinafter called “the Company”) are warranted only as stated below.

Subject to the exceptions and upon the conditions specified below, the Company agrees, at its election, to correct by repair, by replacement, or by credit to the purchaser, any defect of materials or workmanship which develops within one year (13 months for refrigerator and freezer products) from the date of purchase by the original purchaser by the Company or by an authorized dealer of the Company provided that investigation or factory inspection by the Company discloses that such defect developed under normal and proper use

The exceptions and conditions mentioned above are the following:

- a. The Company makes no warranty concerning components or accessories not manufactured by it, such as tubes, batteries, etc. However, in the event of the failure of any component or accessory not manufactured by the Company, the Company will give reasonable assistance to the purchaser in obtaining from the respective manufacturer whatever adjustment is reasonable in the light of the manufacturer’s own warranty.
- b. The Company shall be released from all obligations under its warranty in the event repairs or modifications are made by persons other than its own service personnel or authorized dealer personnel unless such repairs by others are made with the written consent of the Company.
- c. **THE COMPANY MAKES NO WARRANTY OF MERCHANTABILITY, FITNESS FOR ANY PARTICULAR PURPOSE, OR ANY OTHER WARRANTY, EXPRESS OR IMPLIED, EITHER IN FACT OR BY OPERATION OF LAW,...STATUTORY OR OTHERWISE.**
- d. The above warranty and the above obligations to repair, replace, or credit are complete and exclusive and the Company expressly disclaims liability for lost profits or for special, indirect, incidental, consequential, or exemplary damages of any nature whether attributable to contract, warranty, negligence, strict liability, or otherwise even if the Company has been advised of the possibility of such damages.
- e. Representations and warranties made by any person, including dealers and representatives of the Company, which are inconsistent or in conflict with the foregoing warranty shall not be binding upon the Company unless reduced to writing and signed by an officer of the Company.

Important

For your future reference and when contacting the factory, please have the following information readily available:

Model Number : _____

Serial Number : _____

Date Purchased : _____

The above information can be found on the dataplate attached to the equipment. If available, please provide the date purchased, the source of purchase (manufacturer or specific agent/rep organization), and purchase order number.

If you need assistance:

Fisher Scientific products are backed by a global technical support team ready to support your applications. We offer cold storage accessories, including remote alarms, temperature recorders, and validation services.

Visit fishersci.com or call:

SALES DIVISION

Phone 1-828-658-2711
1-800-252-7100

FAX 1-828-645-3368

LABORATORY PARTS and SERVICE

Phone 1-800-438-4851

FAX 1-828-658-2576

TECHNICAL SUPPORT

Phone 1-800-438-4851



Fisher Scientific Inc.

275 Aiken Road
Asheville, NC 28804
United States

057-155-00 Rev.C June 2018

In the United States:

For customer service, call 1-800-766-7000

To fax an order, use 1-800-926-1166

To order online: fishersci.com

