

Superspeed
Fixed-Angle
Rotor Manual



This manual is a guide for the use of

Thermo Scientific Superspeed Fixed-Angle Rotors

Data herein has been verified and is believed adequate for the intended use of the rotor. Because failure to follow the recommendations set forth in this manual could produce personal injury or property damage, always follow the recommendations set forth herein. Thermo Fisher Scientific does not guarantee results and assumes no obligation for the performance of rotors or other products that are not used in accordance with the instructions provided. This publication is not a license to operate under, nor a recommendation to infringe upon, any process patents.

Publications prior to the Issue Date of this manual may contain data in apparent conflict with that provided herein. Please consider all data in this manual to be the most current.

NOTES, CAUTIONS, and WARNINGS within the text of this manual are used to emphasize important and critical instructions.

WARNING informs the operator of a hazard or unsafe practice that could result in personal injury, affect the operator's health, or contaminate the environment.

CAUTION informs the operator of an unsafe practice that could result in damage of equipment.

NOTE highlights essential information.



CAUTION and WARNING are accompanied by a hazard symbol and appear near the information they correspond to.

© 1980, 1997, 1999, 2000, 2003, 2007 2008 by Thermo Fisher Scientific

Important Safety Information

Certain potentially dangerous conditions are inherent to the use of all centrifuge rotors. To ensure safe operation of this rotor, anyone using it should be aware of all safe practices and take all precautions described below and throughout this manual.

WARNING

When using radioactive, toxic, or pathogenic materials, be aware of all characteristics of the materials and the hazards associated with them in the event leakage occurs during centrifugation. If leakage does occur, neither the centrifuge nor the rotor can protect you from the particles dispersed in the air. To protect yourself, we recommend additional precautions be taken to prevent exposure to these material, for example, use of controlled ventilation or isolation areas.

Always be aware of the possibility of contamination when using radioactive, toxic, or pathogenic materials. Take all necessary precautions and use appropriate decontamination procedures if exposure occurs.

Never use any material capable of producing flammable or explosive vapors or creating extreme exothermic reactions.

Never exceed the maximum rated speed of the installed rotor; to do so can cause rotor failure.

Always reduce (derate) rotor speed as instructed in this manual whenever:

- the rotor speed/temperature combination exceeds the solubility of the gradient material and causes it to precipitate.
- the compartment load exceeds the maximum allowable compartment load specified. See Chapter 2, paragraph 2-2.

Failure to reduce rotor speed under these conditions can cause rotor failure.



CAUTION



Do not expose aluminum rotor components to: strong acids, bases, or alkaline laboratory detergents; liquid chlorine bleach; or salts (chlorides) of heavy metals such as cesium, lead, silver, or mercury. Use of these materials with aluminum can cause a chemical reaction that initiates corrosion.

Do not operate or precool the rotor at the critical speed, as this will have a detrimental effect on centrifuge component life. See Chapter 2, paragraphs 2-3.

Do not operate the rotor unless it is symmetrically balanced as described in this manual. Operating the rotor out of balance can cause damage to the centrifuge drive assembly.

Do not operate the rotor without the cover in position and locked in place and the rotor locked to the centrifuge drive. See Chapter 2, paragraph 2-6.

Always maintain the rotor in the recommended manner. The rotor and all accessories must be clean and inspected prior to each run: do not use rotors showing signs of corrosion or cracking. See Chapter 3, Care and Maintenance.

Do not autoclave or expose any aluminum rotor parts to temperatures in excess of 121°C.

Preface

Contents

Preface	Important Safety Information	ii
Chapter 1	Description	
	Rotor Description.....	1-1
	Rotor Specification	1-2
	Replacement Parts.....	1-3
	Tubes, Bottles and Adapter.....	1-6
Chapter 2	Operation	
	Prerun Safety Checks.....	2-1
	Compartment Loads in Excess of Design Mass.....	2-1
	Critical Speed	2-2
	Relative Centrifugal Force (RCF) Determination	2-3
	Calculation of Sedimentation Time in Aqueous (Non-Gradient) Solutions	2-4
	Rotor Loading, Balancing and Sealing	2-5
	Rotor Installation	2-8
	Rotor Speed/Temperature Differential Determination ..	2-9
Chapter 3	Care and maintenance	
	Corrosion	3-1
	Cleaning	3-2
	Storage	3-2
	Inspection	3-3
	Rotor Seal Integrity	3-3
	Service Decontamination Policy	3-6
Appendix		
	RCF Values and K Factor Tables.....	4-1
	Warranty	4-16
	Chemical Compatibility Chart	4-17
	Blank Rotor Speed/Temperature Differential Graphs.	4-24

List of Illustrations

Parts Location: SA-600, SE-12, SM-24 and SS-34 Rotors..... 1-4
 Parts of the SA-300 Rotor 1-5
 Cross Section of Superspeed Fixed-Angle Rotor Showing Radial Distances 2-3
 Determining the Minimum Radius of a Partially-Filled Tube or Bottle..... 2-4
 Rotor Balancing..... 2-6
 Properly Seated ULTRACRIMP® Rotor Cap..... 2-8
 Sample Rotor Speed/Temperature Differential Graphs (Continued) 2-11

List of Tables

Rotor Specifications 1-1
 Parts Identification for the SA-600, SE-12, SM-24 and SS-34 Rotors..... 1-3
 Parts Identification for the SA-300 Rotor..... 1-5
 Maximum Compartment Mass for Each Rotor 2-2
 Critical Speed 2-2
 Rotor Balancing..... 2-6
 SE-12 Rotor: Sealed Tube or Bottle with Maximum Allowable Volume..... 4-1
 SE-12 Rotor: Unsealed Tube or Bottle with Maximum Allowable Volume..... 4-2
 SM-24 Rotor: Sealed Tube or Bottle with Maximum Allowable Volume - OUTER ROW 4-4
 SM-24 Rotor: Sealed Tube or Bottle with Maximum Allowable Volume - INNER ROW 4-6
 SM-24 Rotor: Unsealed Tube or Bottle with Maximum Allowable Volume - OUTER ROW 4-7
 SM-24 Rotor: Unsealed Tube or Bottle with Maximum Allowable Volume - INNER ROW 4-8
 SS-34: Rotor: Sealed Tube or Bottle with Maximum Allowable Volume..... 4-10
 SS-34: Rotor: Unsealed Tube or Bottle with Maximum Allowable Volume..... 4-11
 SA-300: Rotor: Sealed Tube or Bottle with Maximum Allowable Volume..... 4-13
 SA-300: Rotor: Unsealed Tube or Bottle with Maximum Allowable Volume..... 4-14
 Chemical Compatability Charts 4-17

Chapter 1 DESCRIPTION

This manual contains information required to operate and maintain the Thermo Scientific Superspeed Fixed-Angle Rotors: SA-600, SA-300, SE-12, SM-24 and SS-34. If you require additional information regarding operation or maintenance, please contact Thermo Fisher Scientific for assistance. In the United States, call Thermo Fisher Scientific toll-free 1-866-9THERMO; outside the United States, contact the nearest Thermo Fisher Scientific office (see back cover) or your local representative for Thermo Fisher Scientific products. Thermo Scientific product information is available on our internet web site at <http://www.thermo.com/centrifuge>.

Rotor Description

Thermo Scientific Superspeed Fixed-Angle Rotors are designed for use in the Thermo Scientific RC-28S SUPRAspeed[®] Centrifuge¹ RC-26 PLUS, RC-5C PLUS, RC-5C, RC-5B PLUS, RC-5B, RC-6, RC-6+, and Evolution RC Superspeed Centrifuges. The rotors are machined from high strength-to-weight ratio aluminum alloy forgings.

For added safety, the SA-300, SA-600, SE-12, SM-24, and SS-34 rotors are designed to provide biocontainment up to ACDP Category 3.²

Rotor Specifications

Table 1-1 provides the basic specifications for each of the rotors described in this manual.

Table 1-1. Rotor Specifications

	SE-12	SS-34	SM-24	SA-300	SA-600
Diameter	19 cm (7.8 in)	23 cm (9 in)	24 cm (9.13 in)	21 cm (8.27 in)	27 cm (10.75 in)
Mass (weight)	4.1 kg (9 lbs)	6.8 kg (15 lbs)	7.7 kg (17 lbs)	5.6 kg (12 lbs)	10.1 kg (22.5 lbs)

¹The SA-300 Rotor can not be used in the RC-28S Centrifuge.

²Advisory Committee on Dangerous Pathogens (1984), Categorization of pathogens according to hazard and categories of containment, HMSO, ISBN 0 11 883781 3.

Sealed rotors are intended to be part of a biosafety system such as are specified in international and national biosafety guidelines.

Do not rely upon them as the only means of safeguarding yourself and the environment when handling pathogenic microorganisms.

DESCRIPTION
Rotor Specifications

Table 1-1. Rotor Specifications

	SE-12	SS-34	SM-24	SA-300	SA-600
Tube Angle	40°	34°	28°	34°	34°
Number of Places	12	8	24	6	12
Maximum Rotor Speed* (in rpm)	26,000	20,500**	20,500**	25,000	17,000**
Relative Centrifugal Force (RCF) at Maximum Speed***	70,450	50,228	51,965 (Outer Row) 42,717 (Inner Row)	67,509	41,837
K Factor at Maximum Speed**	335	714	434 (Outer Row) 591 (Inner Row)		
Maximum Compartment Mass	30g	115g	27g	115g	115g

* Speed in revolutions per minute (rpm) is related to angular velocity, ω , according to the following:

$$\omega = (\text{rpm}) \left(\frac{2\pi}{60} \right) = (\text{rpm}) (0.10472)$$

Where ω = rad/s. All further references in this manual to speed will be designated as rpm.

**Maximum rotor speed is dependent on the centrifuge used.

***With a sealed tube or bottle containing the maximum allowable volume.

Replacement Parts

Tables 1-2 and 1-3 list part numbers of replacement parts available for each Thermo Scientific Superspeed Fixed-Angle Rotor. Figures 1-1 and 1-2 show parts location.

Table 1-2. Parts Identification for the SA-600, SE-12, SM-24 and SS-34 Rotors

Item	Description	Catalog Number*			
		SA-600	SE-12	SM-24	SS-34
-	Rotor Assembly	28500	27004	29017	28020
	Rotor Cover Assembly (complete)	46531	--	46528	46504
	Rotor Holddown Assembly	46525	--	46525	46525
1	Adapter	28021	28021	28021	28021
2	Cap Screw	63078 (4)	63078 (4)	63078 (4)	63078 (4)
3	Setscrew	60077 (4)	60077 (4)	60077 (4)	60077 (4)
4	Rotor Cover Assembly	12291	27002	29016	28018
5	O-ring (Cover)	60810	61720	60696	60188
6	Cover Sealing Stud	28008	28008	28008	28008
7	Flat Washer (1/4 in)	60751 (2)	60751 (2)	60751 (2)	60751 (2)
8	Lock Washer	63021	63021	63021	63021
9	Cover Stud Top Washer	28010	28010	28010	28010
10	Cover Seat Washer	28011	28011	28011	28011
11	Retaining Ring	60067	60067	60067	60067
12	Cover Seat	28007	28007	28007	28007
13	Cover Clamping Stud	28006	28006	28006	28006
14	O-ring	61616	61616	61616	61616
15	O-ring	60189	60189	60189	60189
-	Extractor Wrench	01031	01031	01031	01031

*Number in parentheses indicates quantity required.

DESCRIPTION
Rotor Specifications

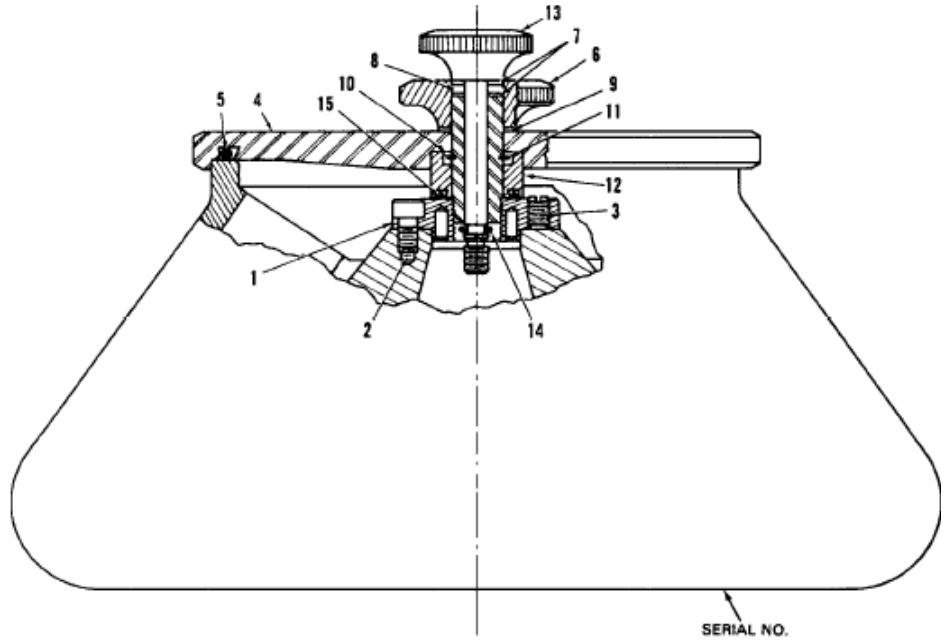

Figure 1-1. Parts Location: SA-600, SE-12, SM-24 and SS-34 Rotors

Table 1-3. Parts Identification for the SA-300 Rotor

Item	Description	Catalog Number
-	Rotor Assembly	18100
-	Rotor Cover Assembly, includes:	18122
1	Rotor Cover	18112
2	Rotor Locking Knob	18115
3	Cover Locking Knob	18111
4	O-Ring, Rotor Locking Knob	61616
5	Retaining Ring, Cover Locking Knob	61882
6	Washer, Cover Knob, Top	60751
7	O-ring, Cover, Viton®	91245
8	O-ring, Cover Knob Shaft, Viton®	67745
9	O-ring, Cover Knob, Viton®	67908
10	Washer, Splitlock, SST	63021
11	Washer, Cover Knob Shaft, SST	11921
12	Washer, Cover Knob, Bottom, Nylon	11936

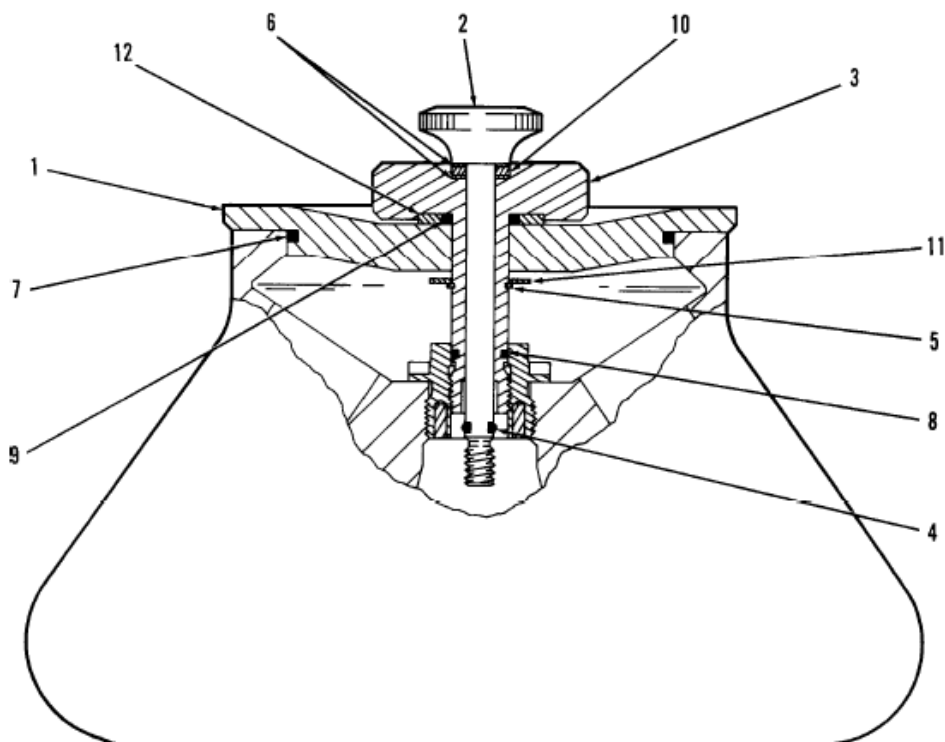

Figure 1-2. Parts of the SA-300 Rotor

Tubes, Bottles and Adapters

Each Thermo Scientific Superspeed Fixed-Angle Rotor accepts a variety of plastic, glass, and stainless steel tubes and bottles. Special adapters permit the use of tubes and bottles other than those which fit the basic rotor compartment. For an up-to-date list and complete description of all available tubes, bottles, and adapters currently available for use with these rotors, please refer to the most current Product Guide. To order or for information, in the United States, call Thermo Fisher Scientific toll-free 1-866-9THERMO; outside the United States, contact the nearest Thermo Scientific office (see back cover) or your local representative for Thermo Fisher Scientific products. Thermo Scientific information is available on our internet web site at <http://www.thermo.com>.

The chemical compatibility of rotor elements and accessory materials is given in the Appendix. This data is to be used only as a guide when selecting a tube or bottle suited for the sample being used.

Chapter 2 OPERATION

Prerun Safety Checks

To ensure safe performance of the rotor, before every run you should:

- a. read the Safety Information Page in the front of this manual.
- b. make sure each tube compartment is clean and shows no sign of corrosion.
- c. be sure the rotor itself is clean and show no sign of corrosion or cracking. Also, make sure there are no scratches or burrs around the rim of the rotor.
- d. check the centrifuge chamber, drive spindle, and tapered mounting surface of the rotor to be sure they are clean and free of scratches and burrs.
- e. check the chemical compatibility of all materials used (see the Appendix).
- f. inspect the rotor cover O-ring and the cover locking knob O-ring for cracks, tears, or abrasions and replace if necessary (see Tables 1-2 , 1-3 and 1-4).
- g. make sure the rotor cover is on and properly tightened (paragraph 2-6).
- h. be sure the proper environment has been selected for operation; for example, controlled ventilation or isolation, if required.

Compartment Loads in Excess of Design Mass

There is a maximum allowable compartment mass established for each superspeed fixed-angle rotor. To prevent rotor failure, the total contents for each compartment, including specimen, tubes, cover, and adapter (if used), should not exceed the figure given in Table 2-1 unless rotor speed is reduced proportionately.

Strict adherence to the maximum allowable compartment mass or reduced speed (see below) is required to prevent rotor failure. Observe the WARNING on the Safety Information Page in the front of this manual.

The rotor speed is reduced in proportion to the square root of the ratio of the maximum allowable compartment mass to the actual mass of the total load. If the compartment mass is more than that specified for the rotor (see Table 2-1) the reduced speed can be determined by using the formula given below.

$$\text{Reduced Speed} = \text{Maximum Speed} \times \sqrt{\frac{\text{Maximum Compartment Mass}}{\text{Actual Compartment Mass (grams)}}}$$

Table 2-1. Maximum Compartment Mass for Each Rotor

Rotor	Maximum Compartment Mass (grams)	Maximum Rotor Speed (rpm)
SS-34	115	20,500
SE-12	30	26,000
SM-24	27	20,500
SA-300	115	25,000
SA-600	115	17,000

Critical Speed

The critical speed is that speed at which any rotor imbalance will produce a driving frequency equal to the resonant frequency of the rotating system (that is, the rotor and centrifuge drive). At this speed, the rotor may produce large amplitude vibrations which can be felt in the instrument frame. Mass imbalance will contribute to increased vibration intensity at the critical speed. Operation at the critical speed will have a detrimental effect on centrifuge component life and therefore, should be avoided (the critical speed for each superspeed fixed-angle rotor is given in Table 2-2). Observe the CAUTION on the Safety Information Page in the front of this manual.

Table 2-2. Critical Speed

Rotor	Thermo Scientific RC-28S* RC-26 PLUS and RC-24 Evolution RC	Thermo Scientific RC-5C PLUS, RC-5C, RC-5B PLUS, RC-5B, RC-6 PLUS, RC-6,
SA-300	1400	1100
SA-600	1200	950
SE-12	1700	1100
SM-24	1300	1100
SS-34	1350	1140

*The SA-300 Rotor can not be used in the RC-28S Centrifuge.

Relative Centrifugal Force (RCF) Determination

Relative Centrifugal Force (RCF) refers to the force during cen-trifugation that moves the particulate outward from the center of rotation. This force is proportional to the radial distance and the square of the rotor speed. RCF is determined by the following formula:

$$RCF = 11.17 (r) \left(\frac{rpm}{1000} \right)^2$$

when r = the radius in centimeters from the centerline of the rotor to the point in the tube where RCF value is required

and rpm= the rotor speed in revolutions per minute

Figure 2-1 shows the point of measurement for the minimum, average and maximum radii of a superspeed fixed angle rotor; the illustration on the left is for a sealed bottle used with the maximum allowable fluid volume, and the one on the right shows an uncapped tube with maximum allowable fluid volume. Tables 4-1 through 4-6 (Section 4) provide the RCF value at each radius for all superspeed fixed-angle rotors at speeds from 1000 rpm to the maximum rotor speed (in increments of 500 rpm).

Note The radii values given are the actual rotor specifications; these values do not take the thickness of the tube (bottle or adapter) into consideration.

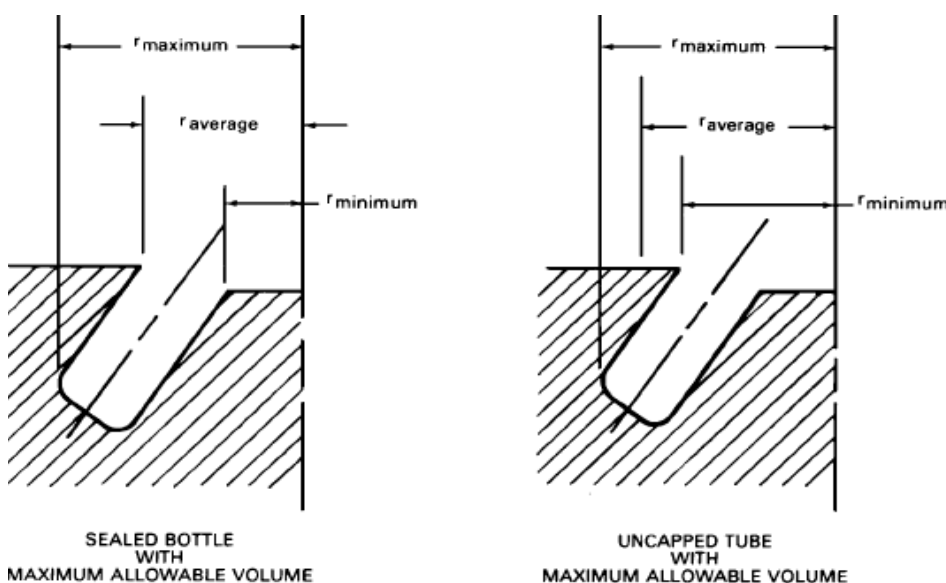

Figure 2-1. Cross Section of Superspeed Fixed-Angle Rotor Showing Radial Distances

If using less than the maximum allowable fluid volume in a tube or a bottle, the minimum and average radius will change depending on the amount of fluid. The maximum radius is a fixed distance that will not change.

OPERATION

Calculation of Sedimentation Times in Aqueous (Non-Gradient) Solutions

The minimum radius is found by subtracting this distance from the maximum radius. The average radius is simply one-half the sum of the minimum and the maximum radii.

The RCF values may now be determined for these radii by using the formula given.

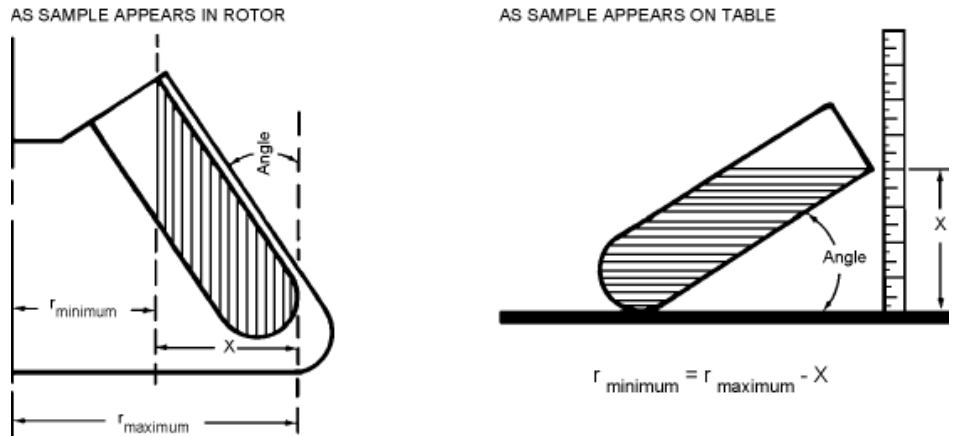

Figure 2-2. Determining the Minimum Radius of a Partially-Filled Tube or Bottle

Calculation of Sedimentation Times in Aqueous (Non-Gradient) Solutions

The time required to sediment a particle in water at 20°C through the maximum rotor path length (that is, the distance between r_{minimum} and r_{maximum}) can be estimated using the equation:

$$t = \frac{K}{S_{20, W}}$$

where:

t = sedimentation time in hours

K = the clearing factor for the rotor (defined below)

$S_{20, W}$ = the sedimentation coefficient for the particle of interest in water at 20°C as expressed in Svedbergs¹

¹The sedimentation coefficient (S) in seconds, for a particle in a centrifugal field is defined by the equation $S = (dx/dt) [1/(\omega^2 x)]$; where dx/dt = sedimentation velocity of the particle in cm/s; ω = rotor speed in rad/s; and x = the distance of the particle from the axis of rotation in centimeters. Conventionally, experimentally determined values of sedimentation coefficients are multiplied by 10^{13} to convert them to Svedberg units (S), so a particle with an experimentally determined sedimentation coefficient of 10^{-11} seconds is usually referred to in the literature as a "100 S particle." Since the value determined for the sedimentation coefficient is dependent on the density and viscosity of the solution in which centrifugation is performed, values are usually reported for the standard conditions of infinite dilution in water at 20°C, and designated $S_{20, w}$.

The clearing, or K, factor is defined by the equation:

$$K = (253\,000) \left[\ln \left(\frac{r_{\text{maximum}}}{r_{\text{minimum}}} \right) \right] \div \left(\frac{\text{rotor speed}}{1000} \right)^2$$

Where r_{maximum} and r_{minimum} are the maximum and minimum rotor radii, respectively, and rotor speed is expressed in rpm.

K factors for the superspeed fixed-angle rotors for speeds from 1000 rpm to the maximum rpm (in increments of 500 rpm) have been listed in Tables 4-1 through 4-6 (Section 4).

Example: The SS-34 Rotor used with unsealed tubes or bottles has a K factor of 381 at the maximum permitted speed (20,500 rpm). If the particles to be sedimented have a sedimentation coefficient of 100 S, the estimated run time required at maximum speed will be:

$$t = \frac{381}{100S} = 3.81 \text{ hours} = 3 \text{ hours, } 49 \text{ minute}$$

Note that the calculation assumes particles in water at 20°C. If the suspending medium is denser or more viscous than water, the sedimentation time will be greater.

Rotor Loading, Balancing and Sealing

The rotor can be operated with either a full or less than full complement of tubes as long as the load is properly balanced. Do not operate the rotor unless it is balanced as described below and illustrated in figure 2-3. Operating the rotor out of balance can cause damage to the centrifuge drive assembly.

- The load in each opposing rotor compartment, including adapters (where applicable), tube, and specimen must be properly balanced within five (5) grams. Rotor imbalance can cause damage to the centrifuge drive.
- When using less than a full complement of tubes, the rotor can be operated at its maximum allowable speed provided opposing pairs of tubes are positioned as shown in figure 2-3.

Note If you are using ULTRACRIMP® tubes in the SA-300 rotor, prepare them for use following the tube filling and tube sealing procedures given in the ULTRACRIMP® Tube Sealing System instruction manual.

OPERATION

Rotor Loading, Balancing and Sealing

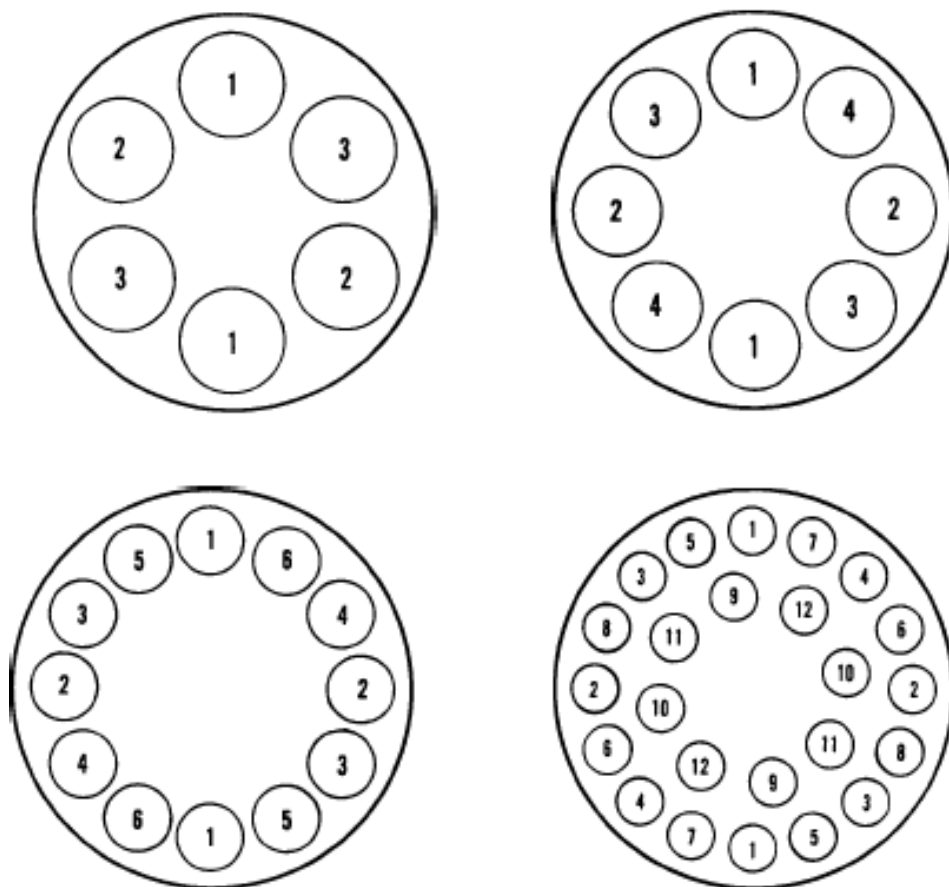

Figure 2-3. Rotor Balancing

Table 2-3. Rotor Balancing

Rotor	
six-place rotor	SA-300
eight-place rotor	SS-34
twelve-place rotor	SE-12, SA-600
twenty-four place rotor	SM-24

Load and seal the SA-300 rotor as follows:

1. Gently load filled tubes into the tube compartments, balancing the rotor as described. If using ULTRACRIMP[®] tubes in the SA-300, insert a rotor cap (Catalog No. 03538) into each tube compartment that contains a filled tube. The rotor cap will seat against top edge of tube compartment (see figure 2-4).

2. Check that the locking knob thread is lightly coated with lubricant, Catalog No. 61556.

Note Apply a light coat of lubricant, to the threads of the rotor locking knob after every five or six runs. The lubricant is supplied with the rotor.

3. Inspect the exposed O-rings on the rotor cover. Apply a thin film of vacuum grease if they are dry (Catalog No. 65937).

Note For the SA-300 rotor, a light coat of vacuum grease must be applied to the rotor cover O-ring and the cover locking knob O-ring every five or six runs to ensure the biocontainment seal works. For location of the O-rings, see figure 1-3. Vacuum grease is supplied with the rotor.

4. Place the rotor cover on the rotor. All superspeed fixed-angle rotors are equipped with double locking knobs on the cover. The larger knob secures the cover to the rotor and the smaller knob secures the rotor to the drive spindle. Before installing the rotor in the centrifuge, tighten the larger knob to tighten the cover to the rotor. The cover is tight when you feel a definite stop in the threads and there is no gap between the rotor body and the cover. Observe the CAUTION.



CAUTION

Do not operate the rotor without the cover securely locked in place. Failure to do so can cause the cover to become disengaged during centrifugation.

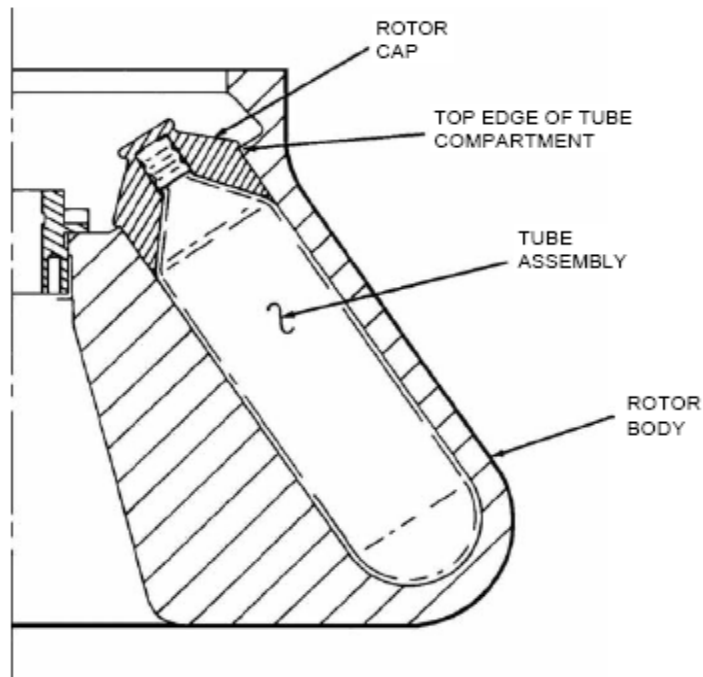

Figure 2-4. Properly Seated ULTRACRIMP® Rotor Cap

Rotor Installation

Before placing the rotor on the tapered spindle of the centrifuge rotor drive, make sure that the rotor centerhole and tapered spindle are clean and free of nicks and scratches. Wipe these surfaces clean before each use. Place the rotor on the tapered spindle and carefully engage the drive pins.

CAUTION



1. Failure to load and install the rotor in accordance with the instructions in the rotor operating guide could result in damage to the centrifuge. The rotor cover must be on and locked in place and the rotor must be locked on the drive spindle.
2. Use specified Thermo Scientific rotors ONLY.
3. Do not incline or move the instrument while the rotor is spinning.
4. Do not place any object on the instrument or lean on the instrument.

Note If the temperature of the rotor chamber is below room temperature, precool the rotor to the lower temperature before securing the rotor in place. Cooling the rotor will minimize the chance of it seizing to the tapered spindle.

Perform the centrifuge run as explained in the centrifuge instruction manual.

Rotor Speed/ Temperature Differential Determination



CAUTION

The temperature offset technique should be used on all runs in an RC-5B and RC-5B PLUS Centrifuge, particularly at either low or high speeds to prevent overtemperature or freezing of sample. This is not necessary when using Evolution RC, RC-6 PLUS, RC-6, RC-28S, RC-26 PLUS, RC-24, RC-5C PLUS or RC-5C Centrifuges; temperature offset is automatic.

Graphs

The rotor speed/temperature differential graphs in figure 2-4 can be used as guides to determine the temperature setting (blue selector) required to maintain a desired sample temperature of 4°C or 20°C. The graphs are approximate since the actual temperature offset (the difference between indicated chamber temperature and sample temperature) depends on the efficiency of the condensing unit and the ambient temperature. The graphs given in figure 2-4 were created using an RC-5B PLUS Centrifuge, therefore, if you are using an RC-5, or RC-5B Centrifuge, the efficiency of the refrigeration system may vary. We recommend performing a test run based on the curves supplied, then adjusting the set temperature accordingly. The required offset is different for each specific rotor. To familiarize yourself with the information given in figure 2-4, refer to the following examples:

Example A: To achieve and maintain a +4.0°C sample temperature using an SE-12 Rotor in an RC-5B PLUS Centrifuge at 15,000 rpm in an ambient temperature of less than 25°C, locate the 4°C Sample curve. Next, find 15,000 rpm using the bottom scale SPEED (rpm x 1000) and follow the line up the graph until it intersects the 4°C Sample curve. In this example, the point corresponds to approximately +1°C. Set the blue TEMPERATURE select needle on the centrifuge for +1°C.

Note An ambient temperature of 25°C or less is required to obtain optimum cooling efficiency. At higher ambient temperatures, a lower set temperature and lower operating speed may be necessary to maintain sample temperature.

For runs at temperatures other than 4°C or 20°C, interpolate to find the set temperature using the appropriate rotor graph given in figure 2-4. Then, do a test run using that interpolated set temperature. Adjust the set temperature upward or downward accordingly. Example B below shows an interpolated set temperature.

OPERATION

Rotor Speed/ Temperature Differential Determination

Example B: To achieve and maintain a +10.0°C sample temperature using an SE-12 Rotor in an RC-5B PLUS Centrifuge at 15,000 rpm in an ambient temperature of less than 25°C, it is necessary to interpolate the set temperature by using the 4°C and 20°C Sample curves as reference. In this example, 10°C at 15,000 rpm would be interpolated to establish a set temperature of approximately 6°C. Set the blue TEMPERATURE select needle on the centrifuge for +6°C.

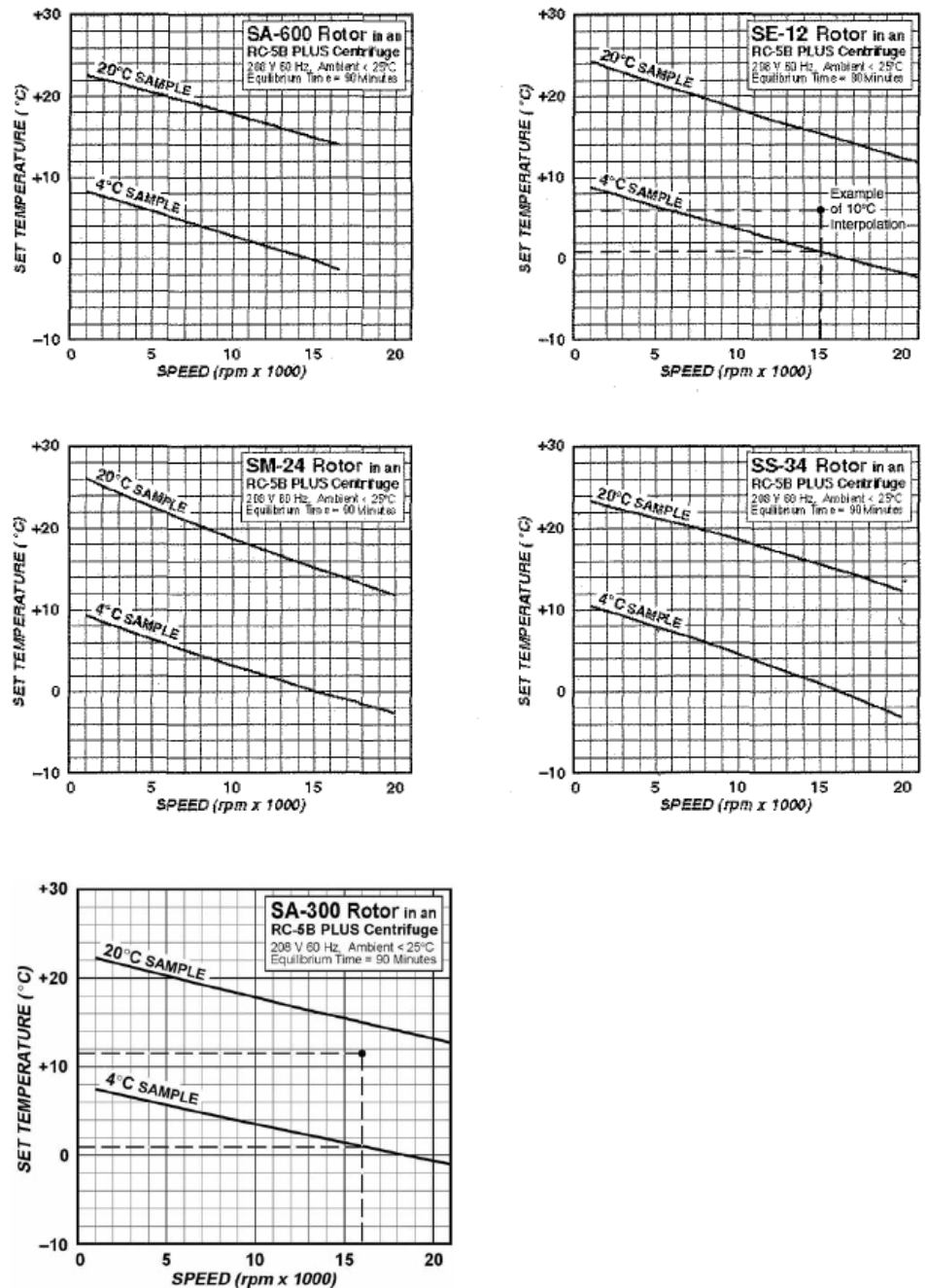

Figure 2-5. Sample Rotor Speed/Temperature Differential Graphs (Continued)

Test Run Procedure

Note To plot set temperature versus actual sample temperature at a specific speed and ambient condition, we recommend doing several test runs at various set temperatures and record the data on one of the blank graphs given in the back of this manual.

Temperature offset data can be determined by doing a test run for a specific rotor/centrifuge/speed and ambient condition. Perform the following steps.

1. Prepare two tubes or bottles of dispensable fluid. Load the prepared tubes or bottles into the rotor and balance the rotor according to paragraph 2-6.

Note The dispensable fluid should have a freezing point somewhat below the desired sample temperature.

2. Precool an immersible centigrade thermometer to 1.0°C below the desired sample temperature.
3. Set the blue TEMPERATURE select needle based on the desired sample temperature.
4. Install the loaded rotor in the centrifuge, close the chamber door, and precool the rotor and samples.
5. Once the rotor and samples are precooled, set the TIME dial to HOLD. Then, perform a run at the desired speed for at least one (1) hour.
6. When an hour has elapsed, stop the run. After the rotor has stopped spinning, open the chamber door and remove the rotor cover. Then, immerse the precooled thermometer into the liquid and agitate the thermometer in the liquid for approximately five (5) to ten (10) seconds. Record the indicated temperature.
7. Adjust the blue TEMPERATURE select needle according to the recorded temperature indication. For example, if the recorded temperature is 2°C warmer than the desired temperature, reset the blue TEMPERATURE select needle downward 2°C.
8. Record all data on the Rotor Speed/Temperature Differential Graphs at the back of this manual for future use.

Note Although the indicated chamber temperature could vary some 2°C during a run, the sample temperature will vary only a few tenths of a degree. In the standby mode, the indicated chamber temperature could vary 10°C with a sample temperature change of $\pm 1^\circ\text{C}$.

OPERATION

Rotor Speed/ Temperature Differential Determination

Chapter 3 CARE and MAINTENANCE

Corrosion

The strong, light-weight aluminum alloy used in the rotor bodies of these rotors is particularly suitable to withstand the stress generated during centrifugation. With proper care, corrosion can be minimized to significantly prolong the useful life of the rotor and lessen the chances of rotor failure and potential damage to the centrifuge.

Corrosion commonly refers to chemical reactions at the surface (that is, rusting or pitting) recognized by growing areas of visible deterioration. On the other hand, stress corrosion attacks the inside of the metal as well; barely detectable surface cracks grow inward, weakening the part without visible warning. Stress corrosion applies to most commonly used alloys, even the corrosion-resistant alloys have been found susceptible.

Stress corrosion is thought to be initiated by certain combinations of stress and chemical reaction. The most common chemical causing harmful effect is chloride, whether in a solution such as ammonium salts or as subtle a form as in hand perspiration. If the rotor is not kept clean and chemicals remain on the rotor, corrosion will result. Also, any moisture left on the rotor for an extended period of time can initiate corrosion; therefore, it is important that all tubes and adapters are removed and then the rotor is thoroughly dried after use.

In general, conditions for corrosion are present in all rotor applications; proper care and maintenance will minimize its effects.

Observe all WARNINGS and CAUTIONS found on the Safety Information Page in the front of this manual.

CAUTION



Do not expose aluminum rotor components to strong acids, bases, or alkaline laboratory detergents; liquid chlorine bleach; or salts (chlorides) or heavy metals such as cesium, lead, silver, or mercury. Use of these materials with aluminum can cause a chemical reaction that initiates corrosion.

WARNING



Always be aware of the possibility of contamination when using radioactive, toxic, or pathogenic materials. Take all necessary precautions and use appropriate decontamination procedures if exposure occurs

Cleaning

These procedures are for general cleaning purposes only. If the rotor or any of its parts are exposed to a contaminant, they must be decontaminated first, then washed to avoid exposure to hazardous materials.

Observe all WARNINGS and CAUTIONS found on the Safety Information Page in the front of this manual.

Wash the rotor with warm water and a mild soap or detergent at least once a week, or ideally after each use. It is particularly important to wash the rotor immediately after any spills have occurred. Most laboratory chemicals can be removed with a lukewarm, 1% solution of a mild, non-alkaline detergent such as a mild dishwashing liquid. Rinse the rotor well, inside and out. After rinsing, dry thoroughly with a soft absorbent cloth or an air blast.

Do not use strong laboratory detergents to clean the rotor surface. Use a bristle brush to loosen encrusted material only if necessary; be careful not to scratch the rotor surface.



CAUTION

Remove the cover assembly from the rotor body before autoclaving. If the cover is left on the rotor during autoclaving, it may deform. If any part of the rotor or cover is subjected to a temperature above 121°C, it should be discarded and replaced.

The rotor body and cover assembly of the SA-300, SA-600, SE-12, SM-24 and SS-34 can be autoclaved separately at 121°C for fifteen minutes at 15 psig. Be sure to remove the rotor cover O-ring before autoclaving.

Use 70% alcohol to disinfect the rotor and/or its components. Ethylene oxide, a 2% glutaraldehyde solution, or ultraviolet radiation are the recommended methods of sterilization.

For general radioactive decontamination, use a solution of equal parts of 70% ethanol, 10% SDS, and water. Follow this with ethanol rinses, then deionized water rinses, and dry with a soft absorbent cloth. Dispose of all wash solutions in proper radioactive waste containers.



CAUTION

Most commercially available radioactive decontamination solutions are not compatible with aluminum.

Storage

After the rotor has been cleaned and dried, it should be stored upside-down, with cover and tubes removed; this will prevent moisture from settling at the bottom of the tube compartments, and will allow air to circulate.

Inspection

Rotor Body and Cover

The rotor body and cover should periodically be inspected for signs of stress, including cracks, tears, or abrasions; wear; corrosion indicated by pitting or scratching; or deformation. Replace any damaged parts. Contact your Thermo Fisher Scientific Authorized Representative for information about the inspection of rotors or rotor replacement.

Biocontainment Seal

To ensure the integrity of the biocontainment seal, inspect the rotor O-rings (shown in figure 1-3) before each run for signs of cracks, tears, or abrasions. Apply vacuum grease if the O-rings are dry. Replace the O-rings if necessary. We also recommend that you test the seal integrity by periodically performing the rotor seal test on the following pages.



WARNING

Because of the characteristics of the samples likely to be processed in the centrifuge, biological or radioactive contamination may occur. Always be aware of this possibility and take normal precautions. Use appropriate decontamination procedures should exposure occur.

Rotor Seal Integrity

The SA-300, SA-600, SM-24, SS-34, and SE-12 rotor is designed to offer increased protection when using hazardous materials; however, it is important to periodically test the cover seal integrity for leakage by performing the following procedure:

1. Remove the rotor cover O-ring (see figure 1-3).
2. Clean the O-ring with warm water and a mild, non-alkaline detergent. Inspect it for signs of cracks, tears, or abrasions. Discard O-ring if it is damaged.
3. Clean the rotor body and cover assembly with warm water and a mild, non-alkaline detergent. Rinse the rotor well inside and out, then dry with a soft absorbent cloth.

Do not use strong laboratory detergents to clean the rotor surface. Use a bristle brush to loosen encrusted material only if necessary. Be careful not to scratch the rotor surface.

4. Inspect the exposed O-ring sealing surfaces on the rotor body and cover assembly to be sure they are clean and free of nicks, scratches, and dents. If any sealing surface is damaged, the part should be replaced or returned for possible service.

Note It is very important that all O-rings and sealing surfaces are carefully inspected, cleaned, and replaced if necessary. If they are not, the rotor will not properly seal.

5. Apply a thin film of vacuum grease, Catalog No. 65937, to the O-rings, including replacement O-rings.
6. Put the O-ring back in its proper position.
7. Place 150 ml of a fluorescein solution (5g fluorescein sodium/liter) into the rotor body. Be careful not to get any solution on the outside of the rotor.
8. Place the rotor cover on the rotor body and securely tighten the cover to the rotor.

Note In steps 9, 10, and 11, hold the rotor over a large shallow pan to collect the rinse water, then transfer each pan of rinse water to a clean container for comparison to other rinse waters. Be sure to rinse and dry the pan between each step.

9. Use 50ml of clean distilled water and rinse the area around the circumference of the rotor between the rotor body and rotor cover. Save the rinse water in a clean, labeled container.
10. Using another 50ml of clean distilled water , rinse the area on top of the rotor cover around the locking knobs. Save this rinse water also in a separate, clean, labeled container.
11. Carefully turn the rotor upside down and rinse the drive adapter and surrounding conical area with still another 50ml of clean distilled water. This rinse water must also be saved in a separate, clean, labeled container.
12. Thoroughly dry the rotor body and cover.
13. Place the rotor upside down on a clean papertowel in a vacuum chamber and draw a 16-inch water column vacuum for three minutes.
14. Remove the rotor and papertowel from the vacuum chamber. Using an ultraviolet light in a dark room, examine the rotor body and the papertowel for traces of fluorescein. If fluorescein is present on the rotor or the papertowel, the seal integrity is considered unacceptable; if unacceptable, proceed to Step 16. Otherwise, proceed to Step 15.

15. Before removing the cover from the rotor, repeat the rinsing procedure in Steps 9, 10, and 11. Thoroughly dry the rotor body and cover.

Using an ultraviolet light in a dark room, compare the fluorescein (if any) between the three containers of rinse water retained from the first rinsing to those retained from the second rinsing.

The seal integrity is considered acceptable if there is no noticeable difference between the rinse water in the two sets of containers. If the rinse water in the second set of containers is more fluorescent than the first set, the seal integrity is unacceptable.

16. If the fluorescein observations in Steps 14 and 15 indicate that the seal is acceptable, proceed to Step 17.

If the seal is unacceptable:

Note If the rotor seal integrity is still not acceptable after following the instructions below, contact your field service engineer.

- a. Empty all fluorescein from the rotor.
- b. Repeat steps 1 through 4 of this procedure for the cover O-ring.
- c. Remove the cover-locking-knob O-rings (refer to figure 1-3) in addition to the cover O-ring (note the parts configuration for reassembly):
 - i. Turn the rotor cover upside down and remove the O-ring on the shaft of the cover locking knob.
 - ii. Remove the retaining ring from the cover knob (with nylon washer) using the retaining ring pliers (Catalog No. 65614) supplied with the centrifuge.
 - iii. Remove the locking knob assembly.
 - iv. Remove the cover knob O-ring (with nylon washer).
- d. Repeat Steps 2 through 6 of this procedure for all O-rings.
- e. Reassemble the rotor cover.

Note The flat side of the retaining ring should face toward you when putting it back into place. Also, the retaining ring must snap into the groove.

- f. Repeat Steps 7 through 14 of this procedure.

17. When the test has been completed, thoroughly rinse and dry the rotor and rotor cover.

Service Decontamination Policy



WARNING

Because of the characteristics of the samples likely to be processed in this centrifuge, biological or radioactive contamination may occur. Always be aware of this possibility, and take normal precautions. Use appropriate decontamination procedures should exposure occur.

If a centrifuge or rotor that has been used with radioactive or pathogenic material requires servicing by Thermo Fisher Scientific personnel, either at the customer's laboratory or at a Thermo Fisher Scientific facility, comply with the following procedures to ensure the safety of all personnel:

1. Clean the centrifuge or rotor to be serviced of all encrusted material and decontaminate it (see Care and maintenance section of centrifuge or rotor instruction manual) prior to servicing by the Thermo Fisher Scientific representative or returning to the Thermo Fisher Scientific facility. There must be no radioactivity detectable by survey equipment.

The Thermo Scientific Product Guide contains descriptions of commonly used decontamination methods and a chart showing method compatibility with various materials. The Care and Maintenance Section of the centrifuge or rotor instruction manual contains specific guidance about cleaning and decontamination methods appropriate for the product it describes.

Clean and decontaminate your centrifuge or rotor as follows:

**For lowspeed, superspeed, and
SUPRAspeed® floor model
centrifuges:**

- a. Remove rotor from the rotor chamber.
- b. Remove, wash, and decontaminate motor sealing gasket and pad.
- c. Decontaminate lid, rotor chamber, and drive using appropriate method.
- d. Remove all encrusted material from around the motor and drive assemblies.

For rotors:

Remove tubes, bottles, and adapters from the rotor and decontaminate rotor using an appropriate method. If tubes or rotor caps are stuck in the rotor, or the rotor lid is stuck, notify a Thermo Scientific representative; be prepared with the name and nature of the sample so the Thermo Fisher Scientific Chemical Hazards Officer can decide whether to authorize the rotor's return to a Thermo Fisher Scientific facility.

Do not leave a loaded rotor locked inside a centrifuge that requires servicing. If, with a loaded rotor installed in the chamber, a centrifuge malfunction makes it so that the chamber door will not open by normal means, follow the Emergency Sample Recovery procedure found in your centrifuge operating instructions manual to gain access to the rotor.

2. Complete and attach Decontamination Information Certificate (in the back of your rotor or instrument manual) to the centrifuge or rotor before servicing.

Decontamination Information Certificates are included with this book. Additional certificates are available from the local Thermo Fisher Scientific Representative or Field Service Engineer. In the event these certificates are not available, a signed, written statement certifying that the unit has been properly decontaminated, identifying what the contaminants were and outlining the decontamination procedures used to be acceptable.



CAUTION

Do not ship or transport a centrifuge with a rotor installed on the drive spindle. If a centrifuge chamber door cannot be opened using conventional methods, refer to the Emergency Sample Recovery (mechanical override) instructions that are provided in your centrifuge operating manual.

Note The Field Service Engineer will note on a Customer Service Repair Report if decontamination was required and, if so, what the contaminant was and what procedure was used. If no decontamination was required, it will be so stated.

If a centrifuge or rotor to be serviced does not have a Decontamination Information Certificate attached, and in Thermo Fisher Scientific's opinion presents a potential radioactive or biological hazard, the Thermo Fisher Scientific representative will not service the equipment until proper decontamination and certification is complete.

If the centrifuge or rotor must be returned to a Thermo Fisher Scientific facility:

1. Contact your Thermo Fisher Scientific representative to obtain an Equipment Return Decontamination Form; be prepared with the name and serial number of the centrifuge or rotor and the repairs required.
2. Complete the Equipment Return Decontamination Form and return it to Thermo Fisher Scientific. Upon request of a completed form, a Returned Material Authorization Number (RMA Number) will be issued to you.
3. With the RMA Number clearly marked on the outside of packaging, send the items to the address obtained from your Thermo Fisher Scientific representative.

Note United States federal regulations require that parts and instruments must be decontaminated before being transported. Outside the United States, check local regulations.

CARE and MAINTENANCE
Service Decontamination Policy

If equipment is received at Thermo Fisher Scientific facilities without a valid RMA Number on the outside of the shipping container and a completed Equipment Return Decontamination Form on file, the equipment will be treated as a potential contamination hazard, and will not be serviced until decontamination has been completed. The sender will be contacted for instructions regarding disposition of the equipment in question; all disposition costs will be borne by the sender. If contaminated equipment is received at Thermo facilities, both the carrier and appropriate authorities will be notified.

SE-12 Rotor: RCF Values and K Factors¹

Table 4-1. Sealed Tube or Bottle with Maximum Allowable Volume

Speed (rpm)	RCF (g force)			K Factor
	r _{maximum} 9.33 cm	r _{average} 6.57 cm	r _{minimum} 3.81 cm	
1,000	104	73	43	226,588
1,500	234	165	96	100,706
2,000	417	294	170	56,647
2,500	651	459	266	36,254
3,000	938	660	383	25,176
3,500	1,277	899	521	18,497
4,000	1,667	1,174	681	14,162
4,500	2,110	1,486	862	11,190
5,000	2,605	1,835	1,064	9,064
5,500	3,153	2,220	1,287	7,491
6,000	3,752	2,652	1,532	6,294
6,500	4,403	3,101	1,798	5,363
7,000	5,107	3,596	2,085	4,624
7,500	5,862	4,128	2,394	4,028
8,000	6,670	4,697	2,724	3,540
8,500	7,530	5,302	3,075	3,136
9,000	8,442	5,944	3,447	2,797
9,500	9,406	6,623	3,841	2,511
10,000	10,422	7,339	4,256	2,266
10,500	11,490	8,091	4,692	2,055
11,000	12,610	8,880	5,149	1,873
11,500	13,783	9,705	5,628	1,713
12,000	15,007	10,568	6,128	1,574
12,500	16,284	11,467	6,650	1,450
13,000	17,613	12,402	7,192	1,341
13,500	18,993	13,375	7,756	1,243
14,000	20,426	14,384	8,341	1,156

¹Values are based on rotor compartment specifications; they do not take the thickness of tube into consideration.

Table 4-1. Sealed Tube or Bottle with Maximum Allowable Volume

Speed (rpm)	RCF (g force)			K Factor
	r _{maximum} 9.33 cm	r _{average} 6.57 cm	r _{minimum} 3.81 cm	
14,500	21,911	15,430	8,948	1,078
15,000	23,449	16,512	9,575	1,007
15,500	25,038	17,631	10,224	943
16,000	26,679	18,787	10,895	885
16,500	28,373	19,980	11,586	832
17,000	30,118	21,209	12,299	784
17,500	31,916	22,475	13,033	740
18,000	33,766	23,777	13,789	699
18,500	35,668	25,117	14,565	662
19,000	37,622	26,493	15,363	628
19,500	39,628	27,905	16,183	596
20,000	41,686	29,355	17,023	566
20,500	43,797	30,841	17,885	539
21,000	45,959	32,364	18,768	514
21,500	48,174	33,923	19,672	490
22,000	50,441	35,519	20,598	468
22,500	52,759	37,152	21,545	448
23,000	55,130	38,822	22,513	428
23,500	57,553	40,528	23,502	410
24,000	60,028	42,271	24,513	393
24 500	62,556	44,050	25,545	377
25,000	65,135	45,867	26,599	363
25,500	67,767	47,720	27,673	348
26,000	70,450	49,610	28,769	335

Table 4-2. Unsealed Tube or Bottle with Maximum Allowable Volume

Speed (rpm)	RCF (g force)			K Factor
	r _{maximum} 9.33 cm	r _{average} 7.27 cm	r _{minimum} 5.21 cm	
1,000	104	81	58	147,412
1,500	234	183	131	65,516
2,000	417	325	233	36,853
2,500	651	508	364	23,586

Table 4-2. Unsealed Tube or Bottle with Maximum Allowable Volume

Speed (rpm)	RCF (g force)			K Factor
	r _{maximum} 9.33 cm	r _{average} 7.27 cm	r _{minimum} 5.21 cm	
3,000	938	731	524	16,379
3,500	1,277	995	713	12,034
4,000	1,667	1,299	931	9,213
4,500	2,110	1,644	1,178	7,280
5,000	2,605	2,030	1,455	5,896
5,500	3,153	2,456	1,760	4,873
6,000	3,752	2,923	2,095	4,095
6,500	4,403	3,431	2,459	2,489
7,000	5,107	3,979	2,852	3,008
7,500	5,862	4,568	3,274	2,621
8,000	6,670	5,197	3,725	2,303
8,500	7,530	5,867	4,205	2,040
9,000	8,442	6,578	4,714	1,820
9,500	9,406	7,329	5,252	1,633
10,000	10,422	8,121	5,820	1,474
10,500	11,490	8,953	6,416	1,337
11,000	12,610	9,826	7,042	1,218
11,500	13,783	10,739	7,697	1,115
12,000	15,007	11,694	8,380	1,024
12,500	16,284	12,688	9,093	943
13,000	17,613	13,724	9,835	872
13,500	18,993	14,800	10,606	809
14,000	20,426	15,916	11,406	752
14,500	21,911	17,074	12,236	701
15,000	23,449	18,271	13,094	655
15,500	25,038	19,510	13,982	614
16,000	26,679	20,789	14,898	576
16,500	28,373	22,108	15,844	541
17,000	30,118	23,469	16,819	510
17,500	31,916	24,869	17,822	481
18,000	33,766	26,311	18,855	455
18,500	35,668	27,793	19,917	431

Table 4-2. Unsealed Tube or Bottle with Maximum Allowable Volume

Speed (rpm)	RCF (g force)			K Factor
	r _{maximum} 9.33 cm	r _{average} 7.27 cm	r _{minimum} 5.21 cm	
19,000	37,622	29,315	21,009	408
19,500	39,628	30,879	22,129	388
20,000	41,686	32,482	23,278	369
20,500	43,797	34,127	24,457	351
21,000	45,959	35,812	25,664	334
21,500	48,174	37,537	26,901	319
22,000	50,441	39,304	28,167	305
22,500	52,759	41,110	29,462	291
23,000	55,130	42,958	30,786	279
23,500	57,553	44,846	32,139	267
24,000	60,028	46,775	33,521	256
24,500	62,556	48,744	34,932	246
25,000	65,135	50,754	36,372	236
25,500	67,767	52,804	37,842	227
26,000	70,450	54,895	39,340	218

SM-24 Rotor: RCF Values and K Factors for Sealed Tube or Bottle with Maximum Allowable Volume

Table 4-3. OUTER ROW

Speed (rpm)	RCF (g force)			K Factor
	r _{maximum} 11.07 cm	r _{average} 8.225 cm	r _{minimum} 5.38 cm	
1,000	124	92	60	182,552
1,500	278	207	135	81,134
2,000	495	367	240	45,638
2,500	773	574	376	29,208
3,000	1,113	827	541	20,284
3,500	1,515	1,125	736	14,902
4,000	1,978	1,470	962	11,410
4,500	2,504	1,860	1,217	9,015
5,000	3,091	2,297	1,502	7,302
5,500	3,740	2,779	1,818	6,035
6,000	4,451	3,307	2,163	5,071

Table 4-3. OUTER ROW

Speed (rpm)	RCF (g force)			K Factor
	r _{maximum} 11.07 cm	r _{average} 8.225 cm	r _{minimum} 5.38 cm	
6,500	5,224	3,882	2,539	4,321
7,000	6,059	4,502	2,945	3,726
7,500	6,955	5,168	3,380	3,245
8,000	7,914	5,880	3,846	2,852
8,500	8,934	6,638	4,342	2,527
9,000	10,016	7,442	4,868	2,254
9,500	11,160	8,292	5,424	2,023
10,000	12,365	9,187	6,009	1,826
10,500	13,633	10,129	6,625	1,656
11,000	14,962	11,117	7,271	1,509
11,500	16,353	12,150	7,948	1,380
12,000	17,806	13,230	8,654	1,268
12,500	19,321	14,355	9,390	1,168
13,000	20,897	15,527	10,156	1,080
13,500	22,536	16,744	10,952	1,002
14,000	24,236	18,007	11,779	931
14,500	25,998	19,316	12,635	868
15,000	27,822	20,671	13,521	811
15,500	29,707	22,073	14,438	760
16,000	31,655	23,520	15,384	713
16,500	33,664	25,012	16,361	671
17,000	35,735	26,551	17,367	632
17,500	37,868	28,136	18,404	596
18,000	40,063	29,767	19,471	563
18,500	42,320	31,444	20,567	533
19,000	44,638	33,166	21,694	506
19,500	47,019	34,935	22,851	480
20,000	49,461	36,749	24,038	456
20,500	51,965	38,610	25,255	434

Table 4-4. INNER ROW

Speed (rpm)	RCF (g force)			K Factor
	r _{maximum} 9.10 cm	r _{average} 6.255 cm	r _{minimum} 3.41 cm	
1,000	102	70	38	248,335
1,500	229	157	86	110,371
2,000	407	279	152	62,084
2,500	635	437	238	39,734
3,000	915	629	343	27,593
3,500	1,245	856	467	20,272
4,000	1,626	1,118	609	15,521
4,500	2,058	1,415	771	12,263
5,000	2,541	1,747	952	9,933
5,500	3,075	2,114	1,152	8,209
6,000	3,659	2,515	1,371	6,898
6,500	4,295	2,952	1,609	5,878
7,000	4,981	3,424	1,866	5,068
7,500	5,718	3,930	2,143	4,415
8,000	6,505	4,472	2,438	3,880
8,500	7,344	5,048	2,752	3,437
9,000	8,233	5,659	3,085	3,066
9,500	9,174	6,306	3,438	2,752
10,000	10,165	6,987	3,809	2,483
10,500	11,207	7,703	4,199	2,252
11,000	12,299	8,454	4,609	2,052
11,500	13,443	9,240	5,037	1,878
12,000	14,637	10,061	5,485	1,725
12,500	15,882	10,917	5,952	1,589
13,000	17,178	11,808	6,437	1,469
13,500	18,525	12,734	6,942	1,363
14,000	19,923	13,694	7,466	1,267
14,500	21,371	14,690	8,008	1,181
15,000	22,871	15,720	8,570	1,104
15,500	24,421	16,786	9,151	1,034
16,000	26,022	17,886	9,751	970
16,500	27,673	19,022	10,370	912

Table 4-4. INNER ROW

Speed (rpm)	RCF (g force)			K Factor
	r _{maximum} 9.10 cm	r _{average} 6.255 cm	r _{minimum} 3.41 cm	
17,000	29,376	20,192	11,008	859
17,500	31,129	21,397	11,665	811
18,000	32,934	22,637	12,341	766
18,500	34,789	23,912	13,036	726
19,000	36,695	25,222	13,750	688
19,500	38,651	26,567	14,484	653
20,000	40,659	27,947	15,236	621
20,500	42,717	29,362	16,007	591

SM-24 Rotor: RCF Values and K Factors for Unsealed Tube or Bottle with Maximum Allowable Volume

Table 4-5. OUTER ROW

Speed (rpm)	RCF (g force)			K Factor
	r _{maximum} 11.07 cm	r _{average} 9.03 cm	r _{minimum} 6.99 cm	
1,000	124	101	78	116,319
1,500	278	227	176	51,697
2,000	495	403	312	29,080
2,500	773	630	488	18,611
3,000	1,113	908	703	12,924
3,500	1,515	1,236	956	9,495
4,000	1,978	1,614	1,249	7,270
4,500	2,504	2,043	1,581	5,744
5,000	3,091	2,522	1,952	4,653
5,500	3,740	3,051	2,362	3,845
6,000	4,451	3,631	2,811	3,231
6,500	5,224	4,262	3,299	2,753
7,000	6,059	4,942	3,826	2,374
7,500	6,955	5,674	4,392	2,068
8,000	7,914	6,455	4,997	1,817
8,500	8,934	7,288	5,641	1,610
9,000	10,016	8,170	6,324	1,436
9,500	11,160	9,103	7,047	1,289

Table 4-5. OUTER ROW

Speed (rpm)	RCF (g force)			K Factor
	r _{maximum} 11.07 cm	r _{average} 9.03 cm	r _{minimum} 6.99 cm	
10,000	12,365	10,087	7,808	1,163
10,500	13,633	11,120	8,608	1,055
11,000	14,962	12,205	9,447	961
11,500	16,353	13,339	10,326	880
12,000	17,806	14,525	11,243	808
12,500	19,321	15,760	12,200	744
13,000	20,897	17,046	13,195	688
13,500	22,536	18,383	14,230	638
14,000	24,236	19,770	15,303	593
14,500	25,998	21,207	16,416	553
15,000	27,822	22,695	17,568	517
15,500	29,707	24,233	18,758	484
16,000	31,655	25,821	19,988	454
16,500	33,664	27,461	21,257	427
17,000	35,735	29,150	22,565	402
17,500	37,868	30,890	23,911	380
18,000	40,063	32,680	25,297	359
18,500	42,320	34,521	26,722	340
19,000	44,638	36,412	28,186	322
19,500	47,019	38,354	29,689	306
20,000	49,461	40,346	31,231	291
20,500	51,965	42,389	32,812	277

Table 4-6. INNER ROW

Speed (rpm)	RCF (g force)			K Factor
	r _{maximum} 9.10 cm	r _{average} 7.06 cm	r _{minimum} 5.02 cm	
1,000	102	79	56	150,496
1,500	229	177	126	66,887
2,000	407	315	224	37,624
2,500	635	493	350	24,079
3,000	915	710	505	16,722
3,500	1,245	966	687	12,285

Table 4-6. INNER ROW

Speed (rpm)	RCF (g force)			K Factor
	r _{maximum} 9.10 cm	r _{average} 7.06 cm	r _{minimum} 5.02 cm	
4,000	1,626	1,262	897	9,406
4,500	2,058	1,597	1,135	7,432
5,000	2,541	1,972	1,402	6,020
5,500	3,075	2,386	1,696	4,975
6,000	3,659	2,839	2,019	4,180
6,500	4,295	3,332	2,369	3,562
7,000	4,981	3,864	2,748	3,071
7,500	5,718	4,436	3,154	2,675
8,000	6,505	5,047	3,589	2,351
8,500	7,344	5,698	4,051	2,083
9,000	8,233	6,388	4,542	1,858
9,500	9,174	7,117	5,061	1,668
10,000	10,165	7,886	5,607	1,505
10,500	11,206	8,694	6,182	1,365
11,000	12,299	9,542	6,785	1,244
11,500	13,443	10,429	7,416	1,138
12,000	14,637	11,356	8,075	1,045
12,500	15,882	12,322	8,761	963
13,000	17,178	13,327	9,476	891
13,500	18,525	14,372	10,219	826
14,000	19,923	15,457	10,990	768
14,500	21,371	16,580	11,789	716
15,000	22,871	17,744	12,617	669
15,500	24,421	18,946	13,472	626
16,000	26,022	20,188	14,355	588
16,500	27,673	21,470	15,266	553
17,000	29,376	22,791	16,205	521
17,500	31,129	24,151	17,172	491
18,000	32,934	25,551	18,168	464
18,500	34,789	26,990	19,191	440
19,000	36,695	28,469	20,242	417
19,500	38,651	29,987	21,322	396

Table 4-6. INNER ROW

Speed (rpm)	RCF (g force)			K Factor
	r _{maximum} 9.10 cm	r _{average} 7.06 cm	r _{minimum} 5.02 cm	
20,000	40,659	31,544	22,429	376
20,500	42,717	33,141	23,565	358

SS-34 Rotor: RCF Values and K Factors**Table 4-7. Sealed Tube or Bottle with Maximum Allowable Volume**

Speed (rpm)	RCF (g force)			K Factor
	r _{maximum} ^{10.} 70 cm	r _{average} 6.985 cm	r _{minimum} 3.27 cm	
1,000	120	78	37	299,920
1,500	269	176	82	133,298
2,000	478	312	146	74,980
2,500	747	488	228	47,987
3,000	1,076	702	329	33,324
3,500	1,464	956	447	24,483
4,000	1,912	1,248	584	18,745
4,500	2,420	1,580	740	14,811
5,000	2,988	1,951	913	11,997
5,500	3,615	2,360	1,105	9,915
6,000	4,303	2,809	1,315	8,331
6,500	5,050	3,296	1,543	7,099
7,000	5,856	3,823	1,790	6,121
7,500	6,723	4,389	2,055	5,332
8,000	7,649	4,993	2,338	4,686
8,500	8,635	5,637	2,639	4,151
9,000	9,681	6,320	2,959	3,703
9,500	10,787	7,042	3,296	3,323
10,000	11,952	7,802	3,653	2,999
10,500	13,177	8,602	4,027	2,720
11,000	14,462	9,441	4,420	2,479
11,500	15,806	10,318	4,831	2,268

Table 4-7. Sealed Tube or Bottle with Maximum Allowable Volume

Speed (rpm)	RCF (g force)			K Factor
	r _{maximum} 10.70 cm	r _{average} 6.985 cm	r _{minimum} 3.27 cm	
12,000	17,211	11,235	5,260	2,083
12,500	18,675	12,191	5,707	1,919
13,000	20,199	13,186	6,173	1,775
13,500	21,782	14,220	6,657	1,646
14,000	23,426	15,292	7,159	1,530
14,500	25,129	16,404	7,680	1,426
15,000	26,892	17,555	8,218	1,333
15,500	28,714	18,745	8,775	1,248
16,000	30,597	19,974	9,351	1,172
16,500	32,539	21,242	9,944	1,102
17,000	34,541	22,548	10,556	1,038
17,500	36,603	23,894	11,186	979
18,000	38,724	25,279	11,834	926
18,500	40,905	26,703	12,501	876
19,000	43,146	28,166	13,186	831
19,500	45,447	29,668	13,889	789
20,000	47,808	31,209	14,610	750
20,500	50,228	32,789	15,530	714

Table 4-8. Unsealed Tube or Bottle with Maximum Allowable Volume

Speed (rpm)	RCF (g force)			K Factor
	r _{maximum} 10.70 cm	r _{average} 8.19 cm	r _{minimum} 5.68 cm	
1,000	120	91	63	160,223
1,500	269	206	143	71,210
2,000	478	366	254	40,056
2,500	747	572	397	25,636
3,000	1,076	823	571	17,803
3,500	1,464	1,121	777	13,079
4,000	1,912	1,464	1,015	10,014
4,500	2,420	1,853	1,285	7,912

Table 4-8. Unsealed Tube or Bottle with Maximum Allowable Volume

Speed (rpm)	RCF (g force)			K Factor
	r _{maximum} 10.70 cm	r _{average} 8.19 cm	r _{minimum} 5.68 cm	
5,000	2,988	2,287	1,586	6,409
5,500	3,615	2,767	1,919	5,297
6,000	4,303	3,293	2,284	4,451
6,500	5,050	3,865	2,681	3,792
7,000	5,856	4,483	3,109	3,270
7,500	6,723	5,146	3,569	2,848
8,000	7,649	5,855	4,061	2,503
8,500	8,635	6,610	4,584	2,218
9,000	9,681	7,410	5,139	1,978
9,500	10,787	8,256	5,726	1,775
10,000	11,952	9,148	6,345	1,602
10,500	13,177	10,086	6,995	1,453
11,000	14,462	11,069	7,677	1,324
11,500	15,806	12,099	8,391	1,212
12,000	17,211	13,173	9,136	1,113
12,500	18,675	14,294	9,913	1,025
13,000	20,199	15,461	10,722	948
13,500	21,782	16,673	11,563	879
14,000	23,426	17,931	12,435	817
14,500	25,129	19,234	13,339	762
15,000	26,892	20,584	14,275	712
15,500	28,714	21,979	15,243	667
16,000	30,597	23,419	16,242	626
16,500	32,539	24,906	17,273	589
17,000	34,541	26,438	18,336	554
17,500	36,603	28,016	19,430	523
18,000	38,724	29,640	20,556	495
18,500	40,905	31,310	21,714	468
19,000	43,146	33,025	22,904	444
19,500	45,447	34,786	24,125	421
20,000	47,808	36,593	25,378	401
20,500	50,228	38,445	26,663	381

SA-300 Rotor: RCF Values and K Factors

Table 4-9. Sealed Tube or Bottle with Maximum Allowable Volume

Speed(rpm)	RCF (g force)			K Factor
	r _{maximum} 9.67 cm	r _{avgerage} 6.01 cm	r _{minimum} 2.35 cm	
2,000	432	269	105	89,474
2,500	675	420	164	57,264
3,000	972	604	236	39,766
3,500	1,323	822	322	29,216
4,000	1,728	1,074	420	22,369
4,500	2,187	1,359	532	17,674
5,000	2,700	1,678	656	14,316
5,500	3,267	2,031	794	11,831
6,000	3,889	2,417	945	9,942
6,500	4,564	2,836	1,109	8,471
7,000	5,293	3,289	1,286	7,304
7,500	6,076	3,776	1,477	6,363
8,000	6,913	4,296	1,680	5,592
8,500	7,804	4,850	1,897	4,954
9,000	8,749	5,438	2,126	4,418
9,500	9,748	6,059	2,369	3,966
10,000	10,801	6,713	2,625	3,579
10,500	11,909	7,401	2,894	3,246
11,000	13,070	8,123	3,176	2,958
11,500	14,285	8,878	3,471	2,706
12,000	15,554	9,667	3,780	2,485
12,500	16,877	10,489	4,101	2,291
13,000	18,254	11,345	4,436	2,118
13,500	19,686	12,235	4,784	1,964
14,000	21,171	13,158	5,145	1,826
14,500	22,710	14,114	5,519	1,702
15,000	24,303	15,105	5,906	1,591
15,500	25,950	16,128	6,306	1,490
16,000	27,652	17,186	6,720	1,398
16,500	29,407	18,277	7,146	1,315
17,000	31,216	19,401	7,586	1,238

Table 4-9. Sealed Tube or Bottle with Maximum Allowable Volume

Speed(rpm)	RCF (g force)			K Factor
	r _{maximum} 9.67 cm	r _{avgerage} 6.01 cm	r _{minimum} 2.35 cm	
17,500	33,079	20,559	8,039	1,169
18,000	34,997	21,751	8,505	1,105
18,500	36,968	22,976	8,984	1,046
19,000	38,993	24,235	9,476	991
19,500	41,072	25,527	9,981	941
20,000	43,206	26,853	10,500	895
20,500	45,393	28,212	11,031	852
21,000	47,634	29,605	11,576	812
21,500	49,929	31,032	12,134	774
22,000	52,279	32,492	12,705	739
22,500	54,682	33,985	13,289	707
23,000	57,139	35,513	13,886	677
23,500	59,651	37,073	14,496	648
24,200	62,216	38,668	15,120	621
24,500	64,835	40,296	15,756	596
25,000	67,509	41,957	16,406	573

Table 4-10. Unsealed Tube or Bottle with Maximum Allowable Volume

Speed(rpm)	RCF (g force)			K Factor
	r _{maximum} 9.67 cm	r _{avgerage} 7.16 cm	r _{minimum} 4.65 cm	
2,000	432	320	208	46,309
2,500	675	500	325	29,638
3,000	972	720	467	20,582
3,500	1,323	980	636	15,121
4,000	1,728	1,280	831	11,577
4,500	2,187	1,620	1,052	9,147
5,000	2,700	1,999	1,299	7,409
5,500	3,267	2,419	1,571	6,124
6,000	3,889	2,879	1,870	5,145
6,500	4,564	3,379	2,194	4,384
7,000	5,293	3,919	2,545	3,780
7,500	6,076	4,499	2,922	3,293

Table 4-10. Unsealed Tube or Bottle with Maximum Allowable Volume

Speed(rpm)	RCF (g force)			K Factor
	r _{maximum} 9.67 cm	r _{average} 7.16 cm	r _{minimum} 4.65 cm	
8,000	6,913	5,119	3,324	2,894
8,500	7,804	5,778	3,753	2,564
9,000	8,749	6,478	4,207	2,287
9,500	9,748	7,218	4,688	2,052
10,000	10,801	7,998	5,194	1,852
10,500	11,909	8,817	5,726	1,680
11,000	13,070	9,677	6,285	1,531
11,500	14,285	10,577	6,869	1,401
12,000	15,554	11,517	7,479	1,286
12,500	16,877	12,496	8,116	1,186
13,000	18,254	13,516	8,778	1,096
13,500	19,686	14,576	9,466	1,016
14,000	21,171	15,676	10,180	945
14,500	22,710	16,815	10,920	881
15,000	24,303	17,995	11,687	823
15,500	25,950	19,215	12,479	771
16,000	27,652	20,474	13,297	724
16,500	29,407	21,774	14,141	680
17,000	31,216	23,113	15,011	641
17,500	33,079	24,493	15,907	605
18,000	34,997	25,913	16,829	572
18,500	36,968	27,372	17,777	541
19,000	38,993	28,872	18,751	513
19,500	41,072	30,411	19,750	487
20,000	43,206	31,991	20,776	463
20,500	45,393	33,610	21,828	441
21,000	47,634	35,270	22,906	420
21,500	49,929	36,969	24,009	401
22,000	52,279	38,709	25,139	383
22,500	54,682	40,488	26,295	366
23,000	57,139	42,308	27,477	350
23,500	59,651	44,167	28,684	335

Table 4-10. Unsealed Tube or Bottle with Maximum Allowable Volume

Speed(rpm)	RCF (g force)			K Factor
	r _{maximum} 9.67 cm	r _{avgerage} 7.16 cm	r _{minimum} 4.65 cm	
24,000	62,216	46,067	29,918	322
24,500	64,835	48,006	31,177	309
25,000	67,509	49,986	32,463	296

Warranty

Thermo Fisher Scientific makes no warranty of any kind, expressed or implied, except as stated in this warranty policy.

Thermo Scientific Superspeed Fixed-Angle Rotors are warranted (subject to the conditions specified below and in the warranty clause of the Thermo Fisher Scientific terms and conditions of sale in effect at the time of sale) against defects in materials or workmanship for ten (10) years at any speed up to the maximum speed of the rotor (properly reduced for certain fluid densities, fluid gradients, tube assemblies, and adapters as described in these operating instructions).

Conditions

- a. This warranty is valid for ten (10) years from the date of shipment to the original buyer by Thermo Fisher Scientific or by an authorized Thermo Fisher Scientific representative.
- b. This warranty extends only to the original buyer and may not be assigned or extended to a third person without the written consent of Thermo
- c. This warranty covers the rotor only and Thermo Fisher Scientific shall not be liable for damage to accessories or ancillary supplies including but not limited to (i) tubes, (ii) tube caps, (iii) tube adapters, or (iv) tube contents.
- d. This warranty is void if the rotor is (i) operated or maintained in a manner contrary to the instructions in the manual for the rotor or centrifuge in use, or (ii) used in a Thermo Scientific Centrifuge that has been modified without the written permission of Thermo.
- e. Should a Thermo Scientific Centrifuge be damaged due to the failure of rotor covered by this warranty, Thermo Fisher Scientific will supply, free of charge, (i) all centrifuge parts required for repair and (ii) if the centrifuge is currently covered by a Thermo Fisher Scientific warranty or service agreement, all labor necessary for repair of the centrifuge.

The foregoing obligation are in lieu of all other obligations and liabilities including negligence and all warranties, of merchantability or otherwise, expressed or implied in fact or by law and state our entire and exclusive liability

and buyer's exclusive remedy for any claim or damages in connection with the sale or furnishings of goods or parts, their design, suitability for use, installation or operation. Thermo Fisher Scientific will in no event be liable for any special or consequential damages whatsoever and our liability under no circumstances will exceed the contract price for the goods for which liability is claimed.

Table 4-11. Chemical Compatibility Chart

CHEMICAL	MATERIAL																											
	ALUMINIUM	ANODIC COATING for ALUMINIUM	BUNA N	CELLULOSE ACETATE BUTYRATE	POLYURETHANE ROTOR PAINT	COMPOSITE Carbon Fiber/Epoxy	DELERIN®	ETHYLENE PROPYLENE	GLASS	NEOPRENE	NORYL®	NYLON	PET, POLYCLEAR™, CLEARCRIMP™, CCLEARCRIMP™	POLYALLOMER	POLYCARBONATE	POLYESTER, GLASS THERMOSET	POLYETHERIMIDE	POLYRTHYLENE	POLYPROPYLENE	POLYSULFONE	POLYVINYL CHLORIDE	RULON A®, TEFLON®	SILICONE RUBBER	STAINLESS STEEL	TITANIUM	TYGON®	VITON®	
Acetaldehyde	S	-	U	U	-	-	-	M	-	U	-	-	-	M	U	U	U	M	M	-	M	S	U	-	S	-	U	
Acetic Acid (5%)	S	S	M	S	S	S	M	S	S	S	S	S	M	S	S	S	S	S	S	S	M	S	S	M	S	S	S	M
Acetic Acid (60%)	S	S	U	U	S	S	U	-	S	M	S	U	U	M	U	S	M	S	M	S	M	S	M	U	S	M	U	
Acetic Acid (Glacial)	S	S	U	U	S	S	U	M	S	U	S	U	U	U	U	U	M	S	U	M	U	S	U	U	S	-	U	
Acetone	M	S	U	U	S	U	M	S	S	U	U	S	U	S	U	U	U	S	S	U	U	S	M	M	S	U	U	
Acetonitrile	S	S	U	-	S	M	S	-	S	S	U	S	U	M	U	U	-	S	M	U	U	S	S	S	S	U	U	
Alconox®	U	U	S	-	S	S	S	-	S	S	S	S	S	S	M	S	S	S	S	S	S	S	S	S	S	S	U	
Allyl Alcohol	-	-	-	U	-	-	S	-	-	-	-	S	-	S	S	M	S	S	S	-	M	S	-	-	S	-	-	
Aluminum Chloride	U	U	S	S	S	S	U	S	S	S	S	M	S	S	S	S	-	S	S	S	S	S	M	U	U	S	S	
Ammonium Acetate	S	S	U	-	S	S	S	-	S	S	S	S	S	S	S	U	-	S	S	S	S	S	S	S	S	S	S	
Ammonium Carbonate	M	S	U	S	S	S	S	S	S	S	S	S	S	S	U	U	-	S	S	S	S	S	S	M	S	S	S	
Ammonium Hydroxide (10%)	U	U	S	U	S	S	M	S	S	S	S	S	-	S	U	M	S	S	S	S	S	S	S	S	S	M	S	
Ammonium Hydroxide (28%)	U	U	S	U	S	U	M	S	S	S	S	S	U	S	U	M	S	S	S	S	S	S	S	S	S	M	S	
Ammonium Hydroxide (conc.)	U	U	U	U	S	U	M	S	-	S	-	S	U	S	U	U	S	S	S	-	M	S	S	S	-	U		
Ammonium Phosphate	U	-	S	-	S	S	S	S	S	S	S	S	-	S	S	M	-	S	S	S	S	S	S	M	S	S	S	
Ammonium Sulfate	U	M	S	-	S	S	U	S	S	S	S	S	S	S	S	S	-	S	S	S	S	S	S	U	S	S	U	
Amyl Alcohol	S	-	M	U	-	-	S	S	-	M	-	S	-	M	S	S	S	S	M	-	-	-	U	-	S	-	M	
Aniline	S	S	U	U	S	U	S	M	S	U	U	U	U	U	U	U	-	S	M	U	U	S	S	S	S	U	S	

Table 4-11. Chemical Compatibility Chart

CHEMICAL	MATERIAL																											
	ALUMINIUM	ANODIC COATING for ALUMINIUM	BUNA N	CELLULOSE ACETATE BUTYRATE	POLYURETHANE ROTOR PAINT	COMPOSITE Carbon Fiber/Epoxy	DELERIN®	ETHYLENE PROPYLENE	GLASS	NEOPRENE	NORYL®	NYLON	PET*, POLYCLEAR™, CLEARCRIMP™, CCCLEARCRIMP™	POLYALLOMER	POLYCARBONATE	POLYESTER, GLASS THERMOSET	POLYETHERIMIDE	POLYRTHYLENE	POLYPROPYLENE	POLYSULFONE	POLYVINYL CHLORIDE	RULON A®, TEFLON®	SILICONE RUBBER	STAINLESS STEEL	TITANIUM	TYGON®	VITON®	
Aqua Regia	U	-	U	U	-	-	U	-	-	-	-	-	U	U	U	U	U	U	U	-	-	-	-	-	S	-	M	
Barium Salts	M	U	S	-	S	S	S	S	S	S	S	S	S	S	S	M	-	S	S	S	S	S	S	S	M	S	S	S
Benzene	S	S	U	U	S	U	M	U	S	U	U	S	U	U	U	M	U	M	U	U	U	S	U	U	S	U	S	
Benzyl Alcohol	S	-	U	U	-	-	M	M	-	M	-	S	U	U	U	U	U	U	U	-	M	S	M	-	S	-	S	
Boric Acid	U	S	S	M	S	S	U	S	S	S	S	S	S	S	S	S	U	S	S	S	S	S	S	S	S	S	S	
N-Butyl Alcohol	S	-	S	U	-	-	S	-	-	S	M	-	U	S	M	S	S	S	S	M	M	S	M	-	S	-	S	
N-Butyl Phthalate	S	S	U	-	S	S	S	-	S	U	U	S	U	U	U	M	-	U	U	S	U	S	M	M	S	U	S	
Calcium Chloride	M	U	S	S	S	S	S	S	S	S	S	S	S	S	M	S	-	S	S	S	S	S	S	M	S	S	S	
Calcium Hypochlorite	M	-	U	-	S	M	M	S	-	M	-	S	-	S	M	S	-	S	S	S	M	S	M	U	S	-	S	
Carbon Tetrachloride	U	U	M	S	S	U	M	U	S	U	U	S	U	M	U	S	S	M	M	S	M	M	M	M	U	S	S	
Cesium Acetate	M	-	S	-	S	S	S	-	S	S	S	S	-	S	S	-	-	S	S	S	S	S	S	M	S	S	S	
Cesium Bromide	M	S	S	-	S	S	S	-	S	S	S	S	S	S	S	-	-	S	S	S	S	S	S	M	S	S	S	
Cesium Chloride	M	S	S	U	S	S	S	-	S	S	S	S	S	S	S	-	-	S	S	S	S	S	S	M	S	S	S	
Cesium Formate	M	S	S	-	S	S	S	-	S	S	S	S	S	S	S	-	-	S	S	S	S	S	S	M	S	S	S	
Cesium Iodide	M	S	S	-	S	S	S	-	S	S	S	S	S	S	S	-	-	S	S	S	S	S	S	M	S	S	S	
Cesium Sulfate	M	S	S	-	S	S	S	-	S	S	S	S	S	S	S	-	-	S	S	S	S	S	S	M	S	S	S	
Chloroform	U	U	U	U	S	S	M	U	S	U	U	M	U	M	U	U	U	M	M	U	U	S	U	U	U	M	S	
Chromic Acid (10%)	U	-	U	U	S	U	U	-	S	S	S	U	S	S	M	U	M	S	S	U	M	S	M	U	S	S	S	
Chromic Acid (50%)	U	-	U	U	-	U	U	-	-	-	S	U	U	S	M	U	M	S	S	U	M	S	-	U	M	-	S	
Citric Acid (10%)	M	S	S	M	S	S	M	S	S	S	S	S	S	S	S	M	S	S	S	S	S	S	S	S	S	S	S	
Cresol Mixture	S	S	U	-	-	-	S	-	S	U	U	U	U	U	U	-	-	U	U	-	U	S	S	S	S	U	S	
Cyclohexane	S	S	S	-	S	S	S	U	S	U	S	S	U	U	U	M	S	M	U	M	M	S	U	M	M	U	S	
Deoxycholate	S	S	S	-	S	S	S	-	S	S	S	S	S	S	S	-	-	S	S	S	S	S	S	S	S	S	S	

Table 4-11. Chemical Compatibility Chart

CHEMICAL	MATERIAL																											
	ALUMINIUM	ANODIC COATING for ALUMINIUM	BUNA N	CELLULOSE ACETATE BUTYRATE	POLYURETHANE ROTOR PAINT	COMPOSITE Carbon Fiber/Epoxy	DELERIN®	ETHYLENE PROPYLENE	GLASS	NEOPRENE	NORYL®	NYLON	PET*, POLYCLEAR™, CLEARCRIMP™, CCCLEARCRIMP™	POLYALLOMER	POLYCARBONATE	POLYESTER, GLASS THERMOSET	POLYETHERIMIDE	POLYTRHTYLENE	POLYPROPYLENE	POLYSULFONE	POLYVINYL CHLORIDE	RULON A®, TEFLON®	SILICONE RUBBER	STAINLESS STEEL	TITANIUM	TYGON®	VITON®	
Dextran	M	S	S	S	S	S	S	-	S	S	S	S	S	S	S	S	S	S	S	S	S	S	S	M	S	S	S	
Diethyl Ether	S	S	U	U	S	S	S	U	S	U	U	S	U	U	U	U	U	U	U	U	U	S	S	S	S	M	U	
Diethyl Ketone	S	-	U	U	-	-	M	-	S	U	-	S	-	M	U	U	U	M	M	-	U	S	-	-	S	U	U	
Diethylpyrocarbonate	S	S	U	-	S	S	S	-	S	S	U	S	U	S	U	-	-	S	S	S	M	S	S	S	S	S	S	
N, N-Dimethylformamide	S	S	S	U	S	M	S	-	S	S	U	S	U	S	U	U	-	S	S	U	U	S	M	S	S	S	U	
Dimethylsulfoxide	S	S	U	U	S	S	S	-	S	U	S	S	U	S	U	U	-	S	S	U	U	S	S	S	S	U	U	
Dioxane	M	S	U	U	S	S	M	M	S	U	U	S	U	M	U	U	-	M	M	M	U	S	S	S	S	U	U	
Distilled Water	S	S	S	S	S	S	S	S	S	S	S	S	S	S	S	S	S	S	S	S	S	S	S	S	S	S	S	
Ethyl Acetate	M	M	U	U	S	S	M	M	S	S	U	S	U	M	U	U	-	S	S	U	U	S	M	M	S	U	U	
Ethyl Alcohol (50%)	S	S	S	S	S	S	M	S	S	S	S	S	U	S	U	S	S	S	S	S	S	S	S	M	S	M	U	
Ethyl Alcohol (95%)	S	S	S	U	S	S	M	S	S	S	S	S	U	S	U	-	S	S	S	M	S	S	S	U	S	M	U	
Ethylene Dichloride	S	-	U	U	-	-	S	M	-	U	U	S	U	U	U	U	U	U	U	-	U	S	U	-	S	-	S	
Ethylene Glycol	S	S	S	S	S	S	S	S	S	S	S	S	-	S	U	S	S	S	S	S	S	S	S	M	S	M	S	
Ethylene Oxide Vapor	S	-	U	-	-	U	-	-	S	U	-	S	-	S	M	-	-	S	S	S	U	S	U	S	S	U	U	
Ferric Chloride	U	U	S	-	-	-	M	S	-	M	-	S	-	S	-	-	-	S	S	-	-	-	M	U	S	-	S	
Ficoll-Hypaque®	M	S	S	-	S	S	S	-	S	S	S	S	-	S	S	-	S	S	S	S	S	S	S	M	S	S	S	
Formaldehyde (40%)	M	M	M	S	S	S	S	M	S	S	S	S	M	S	S	S	U	S	S	M	S	S	S	M	S	M	U	
Formic Acid (100%)	-	S	M	U	-	-	U	-	-	-	-	U	-	S	M	U	U	S	S	-	U	S	-	U	S	-	U	
Glutaraldehyde	S	S	S	S	-	-	S	-	S	S	S	S	S	S	S	-	-	S	S	S	-	-	S	S	S	-	-	
Glycerol	M	S	S	-	S	S	S	S	S	S	S	S	S	S	S	S	-	S	S	S	S	S	S	S	S	S	S	
Guanidine Hydrochloride	U	U	S	-	S	S	S	-	S	S	S	S	S	S	S	-	-	S	S	S	S	S	S	U	S	S	S	
Haemo-Sol®	S	S	S	-	-	-	S	-	S	S	S	S	S	S	S	-	-	S	S	S	S	S	S	S	S	S	S	
Hexane	S	S	S	-	S	S	S	-	S	S	U	S	U	M	U	S	S	U	S	S	M	S	U	S	S	U	S	

Table 4-11. Chemical Compatibility Chart

CHEMICAL	MATERIAL																										
	ALUMINIUM	ANODIC COATING for ALUMINIUM	BUNA N	CELLULOSE ACETATE BUTYRATE	POLYURETHANE ROTOR PAINT	COMPOSITE Carbon Fiber/Epoxy	DELERIN®	ETHYLENE PROPYLENE	GLASS	NEOPRENE	NORYL®	NYLON	PET*, POLYCLEAR™, CLEARCRIMP™, CCCLEARCRIMP™	POLYALLOMER	POLYCARBONATE	POLYESTER, GLASS THERMOSET	POLYETHERIMIDE	POLYRTHYLENE	POLYPROPYLENE	POLYSULFONE	POLYVINYL CHLORIDE	RULON A®, TEFLON®	SILICONE RUBBER	STAINLESS STEEL	TITANIUM	TYGON®	VITON®
Hydrochloric Acid (10%)	U	U	M	S	S	S	U	-	S	S	S	U	U	S	U	S	S	S	S	S	S	S	S	U	M	S	S
Hydrochloric Acid (50%)	U	U	U	U	S	U	U	-	S	M	S	U	U	M	U	U	S	S	S	S	M	S	M	U	U	M	M
Hydrochloric Acid (conc.)	U	U	U	U	-	U	U	M	-	U	M	U	U	M	U	U	U	-	S	-	U	S	U	U	U	-	-
Hydrofluoric Acid (10%)	U	U	U	M	-	-	U	-	-	U	U	S	-	S	M	U	S	S	S	S	M	S	U	U	U	-	-
Hydrofluoric Acid (50%)	U	U	U	U	-	-	U	-	-	U	U	U	U	S	U	U	U	S	S	M	M	S	U	U	U	-	M
Hydrogen Peroxide (3%)	S	M	S	S	S	-	S	-	S	S	S	S	S	S	S	S	M	S	S	S	S	S	S	S	S	S	S
Hydrogen Peroxide (10%)	U	U	M	S	S	U	U	-	S	S	S	U	S	S	S	M	U	S	S	S	S	S	S	M	S	U	S
Iodoacetic Acid	S	S	M	-	S	S	S	-	S	M	S	S	M	S	S	-	M	S	S	S	S	S	M	S	S	M	M
Isobutyl Alcohol	-	-	M	U	-	-	S	S	-	U	-	S	U	S	S	M	S	S	S	-	S	S	S	-	S	-	S
Isopropyl Alcohol	M	M	M	U	S	S	S	S	S	U	S	S	U	S	U	M	S	S	S	S	S	S	S	M	M	M	S
Kerosene	S	S	S	-	S	S	S	U	S	M	U	S	U	M	M	S	-	M	M	M	S	S	U	S	S	U	S
Lactic Acid (20%)	-	-	S	S	-	-	-	-	-	M	S	M	-	S	S	S	S	S	S	S	M	S	M	S	S	-	S
Lactic Acid (100%)	-	-	S	-	-	-	-	-	-	M	S	U	-	S	S	S	M	S	S	-	M	S	M	S	S	-	S
Magnesium Chloride	M	S	S	-	S	S	S	S	S	S	S	S	S	S	S	S	S	S	S	S	S	S	S	M	S	S	S
Mercaptoacetic Acid	U	S	U	-	S	M	S	-	S	M	S	U	U	U	U	-	S	U	U	S	M	S	U	S	S	S	S
2-Mercaptoethanol	S	S	U	-	S	M	S	-	S	U	S	S	U	S	S	-	S	S	S	S	U	S	S	S	S	S	S
Metrizamide®	M	S	S	-	S	S	S	-	S	S	S	S	-	S	S	-	-	S	S	S	S	S	S	M	S	S	S
Methyl Alcohol	S	S	S	U	S	S	M	S	S	S	S	S	U	S	U	M	S	S	S	S	S	S	S	M	S	M	U
Methyl Ethyl Ketone	S	S	U	U	S	S	M	S	S	U	U	S	U	S	U	U	U	S	S	U	U	S	S	S	S	U	U
Methylene Chloride	U	U	U	U	M	S	S	U	S	U	U	S	U	U	U	U	U	M	U	U	U	S	S	M	U	S	U
Nickel Salts	U	S	S	S	S	S	-	S	S	S	-	-	S	S	S	S	-	S	S	S	S	S	S	M	S	S	S
Nitric Acid (10%)	U	S	U	S	S	U	U	-	S	U	S	U	-	S	S	S	S	S	S	S	S	S	M	S	S	S	S
Nitric Acid (50%)	U	S	U	M	S	U	U	-	S	U	S	U	U	M	M	U	M	M	M	S	S	S	U	S	S	M	S

Table 4-11. Chemical Compatibility Chart

CHEMICAL	MATERIAL	ALUMINIUM	ANODIC COATING for ALUMINIUM	BUNA N	CELLULOSE ACETATE BUTYRATE	POLYURETHANE ROTOR PAINT	COMPOSITE Carbon Fiber/Epoxy	DELERIN®	ETHYLENE PROPYLENE	GLASS	NEOPRENE	NORYL®	NYLON	PET ⁺ , POLYCLEAR™, CLEARCRIMP™, CCCLEARCRIMP™	POLYALLOMER	POLYCARBONATE	POLYESTER, GLASS THERMOSET	POLYETHERIMIDE	POLYETHYLENE	POLYPROPYLENE	POLYSULFONE	POLYVINYL CHLORIDE	RULON A®, TEFLON®	SILICONE RUBBER	STAINLESS STEEL	TITANIUM	TYGON®	VITON®	
Nitric Acid (95%)		U	-	U	U	-	U	U	-	-	U	U	U	U	M	U	U	U	U	M	U	U	S	U	S	S	-	S	
Oils (Petroleum)		S	S	S	-	-	-	S	U	S	S	S	S	U	U	M	S	M	U	U	S	S	S	U	S	S	S	S	
Oils (Other)		S	-	S	-	-	-	S	M	S	S	S	S	U	S	S	S	S	U	S	S	S	S	-	S	S	M	S	
Oleic Acid		S	-	U	S	S	S	U	U	S	U	S	S	M	S	S	S	S	S	S	S	S	S	M	U	S	M	M	
Oxalic Acid		U	U	M	S	S	S	U	S	S	S	S	S	U	S	U	S	S	S	S	S	S	S	S	U	M	S	S	
Perchloric Acid (10%)		U	-	U	-	S	U	U	-	S	M	M	-	-	M	U	M	S	M	M	-	M	S	U	-	S	-	S	
Perchloric Acid (70%)		U	U	U	-	-	U	U	-	S	U	M	U	U	M	U	U	U	M	M	U	M	S	U	U	S	U	S	
Phenol (5%)		U	S	U	-	S	M	M	-	S	U	M	U	U	S	U	M	S	M	S	U	U	S	U	M	M	M	S	
Phenol (50%)		U	S	U	-	S	U	M	-	S	U	M	U	U	U	U	U	S	U	M	U	U	S	U	U	U	M	S	
Phosphoric Acid (10%)		U	U	M	S	S	S	U	S	S	S	S	U	-	S	S	S	S	S	S	S	S	S	U	M	U	S	S	
Phosphoric Acid (conc.)		U	U	M	M	-	-	U	S	-	M	S	U	U	M	M	S	S	S	M	S	M	S	U	M	U	-	S	
Physiologic Media (Serum, Urine)		M	S	S	S	-	-	S	-	S	S	S	S	S	S	S	S	S	S	S	S	S	S	S	S	S	S	S	
Picric Acid		S	S	U	-	S	M	S	S	S	M	S	U	S	S	S	U	S	S	S	S	U	S	U	M	S	M	S	
Potassium Bromide		U	S	S	-	S	S	S	-	S	S	S	S	S	S	S	S	S	S	S	S	-	S	S	S	M	S	S	S
Potassium Carbonate		M	U	S	S	S	S	S	-	S	S	S	S	S	S	U	S	S	S	S	S	S	S	S	S	S	S	S	
Potassium Chloride		U	S	S	-	S	S	S	S	S	S	S	S	S	S	S	-	S	S	S	S	S	S	S	U	S	S	S	
Potassium Hydroxide (5%)		U	U	S	S	S	S	M	-	S	S	S	S	-	S	U	S	S	S	S	S	S	S	M	U	M	S	U	
Potassium Hydroxide (conc.)		U	U	M	U	-	-	M	-	M	S	S	-	U	M	U	U	U	S	M	-	M	U	-	U	U	-	U	
Potassium Permanganate		S	S	S	-	S	S	S	-	S	S	S	U	S	S	S	M	-	S	M	S	U	S	S	M	S	U	S	
Pyridine (50%)		U	S	U	U	S	U	U	-	U	S	S	U	U	M	U	U	-	U	S	M	U	S	S	U	U	U	U	
Rubidium Bromide		M	S	S	-	S	S	S	-	S	S	S	S	S	S	S	-	-	S	S	S	S	S	S	M	S	S	S	
Rubidium Chloride		M	S	S	-	S	S	S	-	S	S	S	S	S	S	S	-	-	S	S	S	S	S	S	M	S	S	S	
Sodium Borate		M	S	S	S	S	S	S	S	S	S	U	S	S	S	S	S	-	S	S	S	S	S	S	M	S	S	S	

Table 4-11. Chemical Compatibility Chart

CHEMICAL	MATERIAL	ALUMINIUM	ANODIC COATING for ALUMINIUM	BUNA N	CELLULOSE ACETATE BUTYRATE	POLYURETHANE ROTOR PAINT	COMPOSITE Carbon Fiber/Epoxy	DELERIN®	ETHYLENE PROPYLENE	GLASS	NEOPRENE	NORYL®	NYLON	PET*, POLYCLEAR™, CLEARCRIMP™, CCCLEARCRIMP™	POLYALLOMER	POLYCARBONATE	POLYESTER, GLASS THERMOSET	POLYETHERIMIDE	POLYRTHYLENE	POLYPROPYLENE	POLYSULFONE	POLYVINYL CHLORIDE	RULON A®, TEFLON®	SILICONE RUBBER	STAINLESS STEEL	TITANIUM	TYGON®	VITON®	
Sodium Bromide	U	S	S	-	S	S	S	S	-	S	S	S	S	S	S	S	S	-	S	S	S	S	S	S	M	S	S	S	
Sodium Carbonate (2%)	M	U	S	S	S	S	S	S	S	S	S	S	S	S	S	U	S	S	S	S	S	S	S	S	S	S	S	S	S
Sodium Chloride (10%)	S	-	S	S	S	S	S	S	-	-	-	S	S	S	S	S	S	-	S	S	S	S	-	S	S	M	-	S	
Sodium Chloride (sat'd)	U	-	S	U	S	S	S	-	-	-	-	S	S	S	S	S	S	-	S	S	-	S	-	S	S	M	-	S	
Sodium Dodecyl Sulfate	S	S	S	-	S	S	S	-	S	S	S	S	S	S	S	S	-	S	S	S	S	S	S	S	S	S	S	S	
Sodium Hydroxide (<1%)	U	-	M	S	S	S	-	-	S	M	S	S	-	S	M	M	S	S	S	S	S	S	S	M	S	S	-	U	
Sodium Hydroxide (10%)	U	-	M	U	-	-	U	-	M	M	S	S	U	S	U	U	S	S	S	S	S	S	S	M	S	S	-	U	
Sodium Hypochlorite (5%)	U	U	M	S	S	M	U	S	S	M	S	S	S	M	S	S	S	S	S	M	S	S	M	U	S	M	S		
Sodium Iodide	M	S	S	-	S	S	S	-	S	S	S	S	S	S	S	-	-	S	S	S	S	S	S	M	S	S	S		
Sodium Nitrate	S	S	S	-	S	S	S	S	S	S	S	S	S	S	S	S	-	S	S	S	S	S	S	U	S	S	S		
Sodium Sulfate	U	S	S	-	S	S	S	S	S	S	S	S	S	S	S	S	S	S	S	S	S	S	S	M	S	S	S		
Sodium Sulfide	S	-	S	S	-	-	-	S	-	-	-	S	S	S	U	U	-	-	S	-	-	-	S	S	M	-	S		
Sodium Sulfite	S	S	S	-	S	S	S	M	S	S	S	S	S	S	M	-	S	S	S	S	S	S	S	S	S	S	S		
Stearic Acid	S	-	S	-	-	-	S	M	S	S	S	S	-	S	S	S	S	S	S	S	S	S	M	M	S	S	S		
Sucrose	M	S	S	-	S	S	S	S	S	S	S	S	S	S	S	S	S	S	S	S	S	S	S	S	S	S	S		
Sucrose, Alkaline	M	S	S	-	S	S	S	-	S	S	S	S	S	S	U	S	S	S	S	S	S	S	S	M	S	S	S		
Sulfosalicylic Acid	U	U	S	S	S	S	S	-	S	S	S	U	S	S	S	-	S	S	S	-	S	S	S	U	S	S	S		
Sulfuric Acid (10%)	M	U	U	S	S	U	U	-	S	S	M	U	S	S	S	S	S	S	S	S	S	S	U	U	U	S	S		
Sulfuric Acid (50%)	M	U	U	U	S	U	U	-	S	S	M	U	U	S	U	U	M	S	S	S	S	S	U	U	U	M	S		
Sulfuric Acid (conc.)	M	U	U	U	-	U	U	M	-	-	M	U	U	S	U	U	U	M	S	U	M	S	U	U	U	-	S		
Solution 555 (20%)	S	S	S	-	-	-	S	-	S	S	S	S	S	S	S	-	-	S	S	S	-	S	S	S	S	S	S		
Tetrahydrofuran	S	S	U	U	S	U	U	M	S	U	U	S	U	U	U	-	M	U	U	U	U	S	U	S	S	U	U		
Tris Buffer (neutral pH)	U	S	S	S	S	S	S	-	S	S	S	S	S	S	S	S	S	S	S	S	S	S	S	S	S	S	S		

Table 4-11. Chemical Compatibility Chart

CHEMICAL	MATERIAL	ALUMINIUM	ANODIC COATING for ALUMINIUM	BUNA N	CELLULOSE ACETATE BUTYRATE	POLYURETHANE ROTOR PAINT	COMPOSITE Carbon Fiber/Epoxy	DELERIN®	ETHYLENE PROPYLENE	GLASS	NEOPRENE	NORYL®	NYLON	PET*, POLYCLEAR™, CLEARCRIMP™, CCCLEARCRIMP™	POLYALLOMER	POLYCARBONATE	POLYESTER, GLASS THERMOSET	POLYETHERIMIDE	POLYRTHYLENE	POLYPROPYLENE	POLYSULFONE	POLYVINYL CHLORIDE	RULON A®, TEFLON®	SILICONE RUBBER	STAINLESS STEEL	TITANIUM	TYGON®	VITON®
Toluene		S	S	U	U	S	S	M	U	S	U	U	S	U	U	U	S	U	M	U	U	U	S	U	S	U	U	M
Trichloroacetic Acid		U	U	U	-	S	S	U	M	S	U	S	U	U	S	M	-	M	S	S	U	U	S	U	U	U	M	U
Trichloroethane		S	-	U	-	-	-	M	U	-	U	-	S	U	U	U	U	U	U	U	U	U	S	U	-	S	-	S
Trichloroethylene		-	-	U	U	-	-	-	U	-	U	-	S	U	U	U	U	U	U	U	U	U	S	U	-	U	-	S
Trisodium Phosphate		-	-	-	S	-	-	M	-	-	-	-	-	-	S	-	-	S	S	S	-	-	S	-	-	S	-	S
Triton X-100®		S	S	S	-	S	S	S	-	S	S	S	S	S	S	S	S	S	S	S	S	S	S	S	S	S	S	S
Urea		S	-	U	S	S	S	S	-	-	-	-	S	S	S	M	S	S	S	S	-	S	S	S	M	S	-	S
Xylene		S	S	U	S	S	S	M	U	S	U	U	U	U	U	M	U	M	U	U	U	U	S	U	M	S	U	S
Zinc Chloride		U	U	S	S	S	S	U	S	S	S	S	S	S	S	S	S	S	S	S	S	S	S	S	U	S	S	S
Zinc Sulfate		U	S	S	-	S	S	S	S	S	S	S	S	S	S	S	S	S	S	S	S	S	S	S	S	S	S	S

*Polyethyleneterephthalate

KEY S = Satisfactory

M = Moderate attack, may be satisfactory for use in centrifuge depending on length of exposure, speed involved, etc.; suggest testing under actual conditions of use.

U = Unsatisfactory, not recommended.

-- = Performance unknown; suggest testing, using sample to avoid loss of valuable material.

Chemical resistance data is included only as a guide to product use. Because no organized chemical resistance data exists for materials under the stress of centrifugation, when in doubt we recommend pretesting of sample lots.

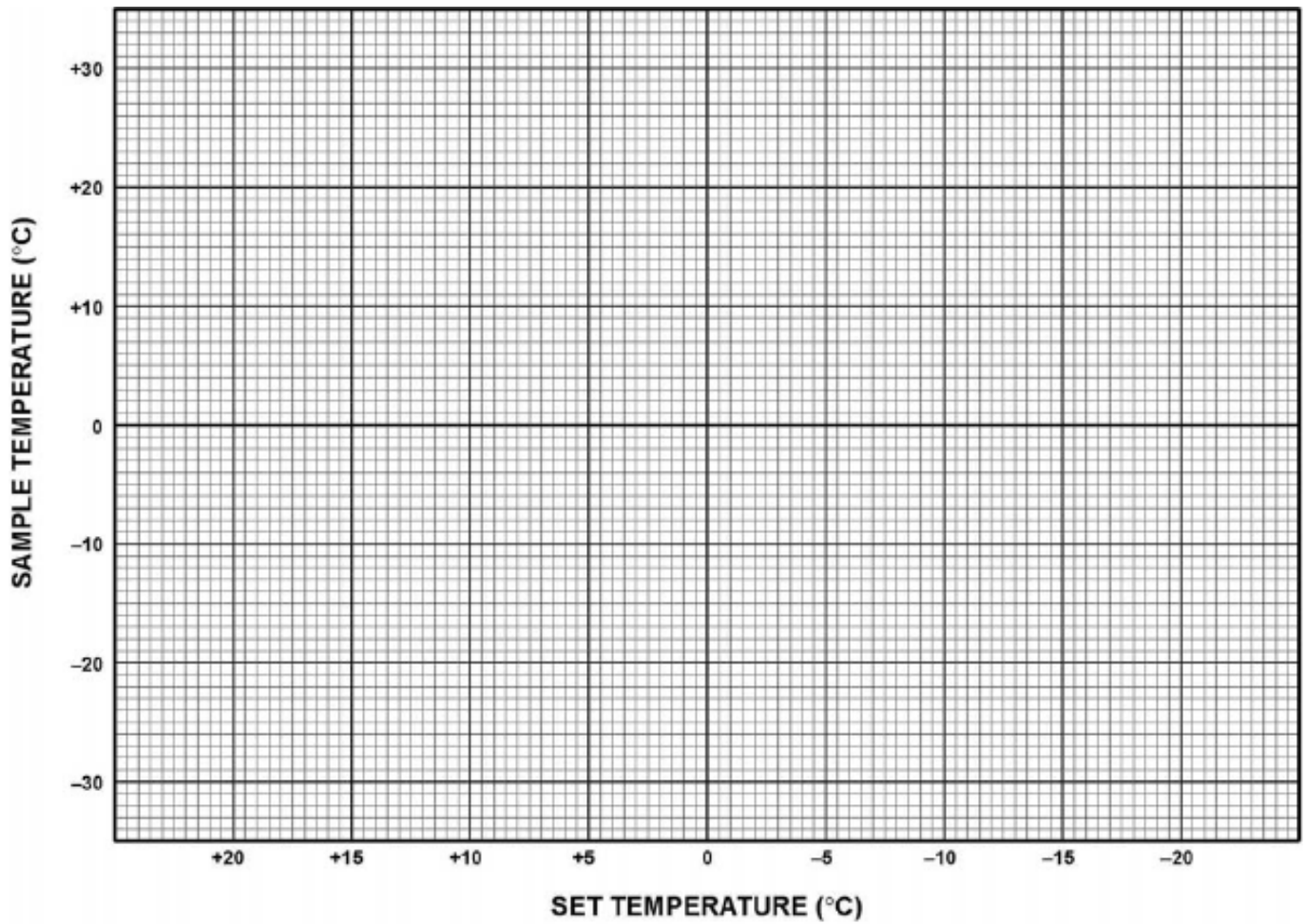

Rotor Speed/Temperature Differential Chart for

Rotor _____

Instrument _____

Ambient Temperature _____

Rotor Speed _____

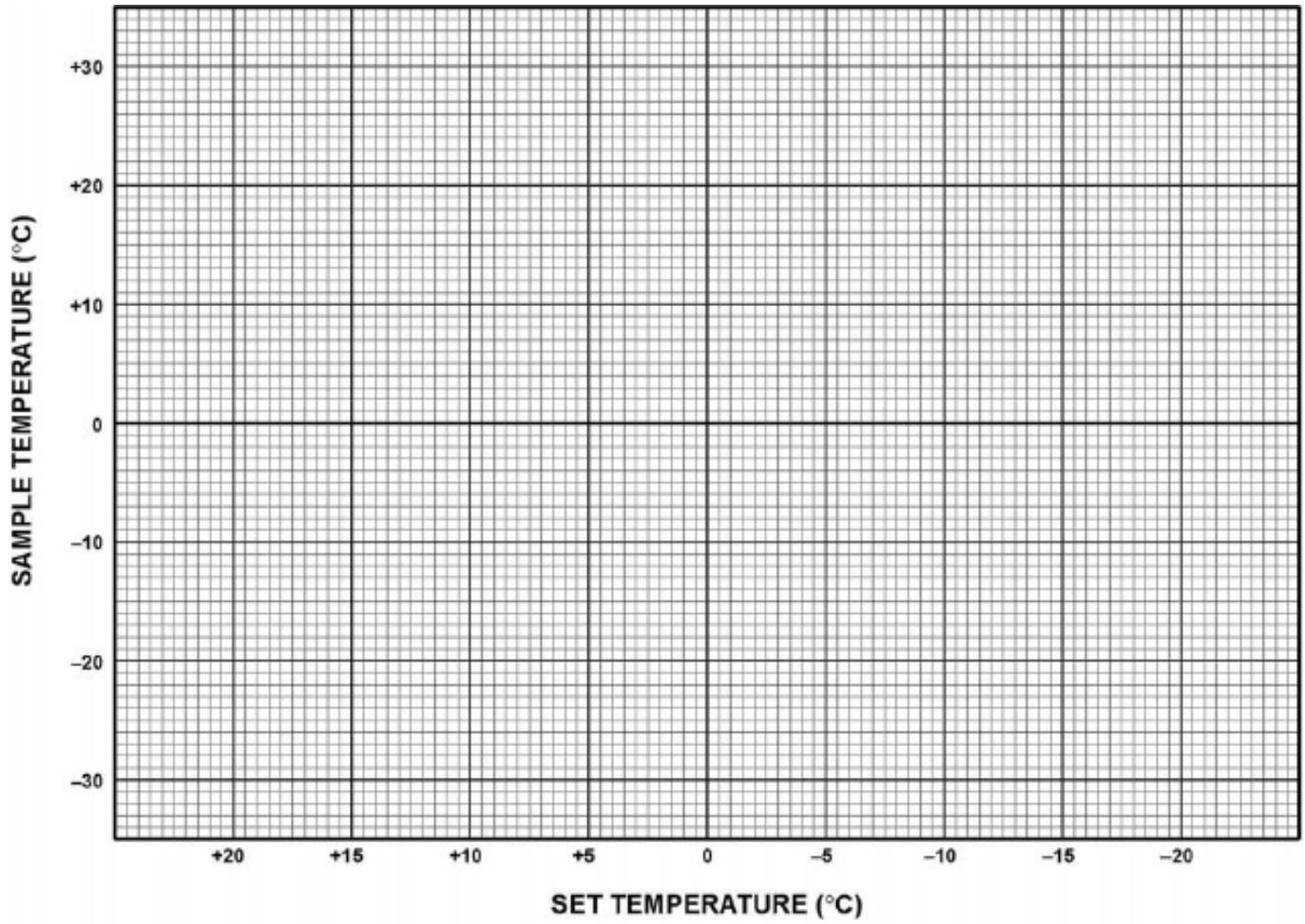

Rotor Speed/Temperature Differential Chart for

Rotor _____

Instrument _____

Ambient Temperature _____

Rotor Speed _____

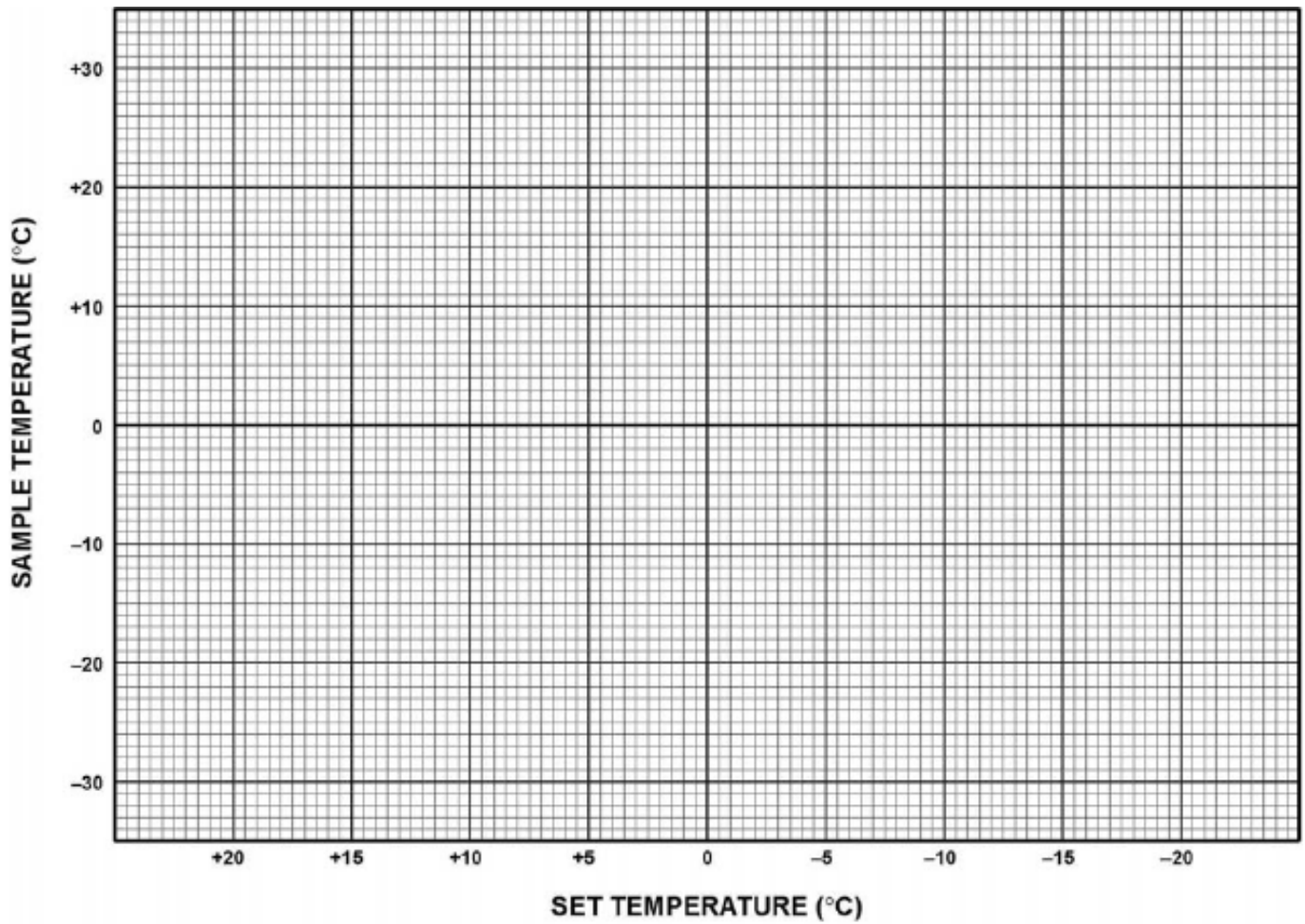

Rotor Speed/Temperature Differential Chart for

Rotor _____

Instrument _____

Ambient Temperature _____

Rotor Speed _____

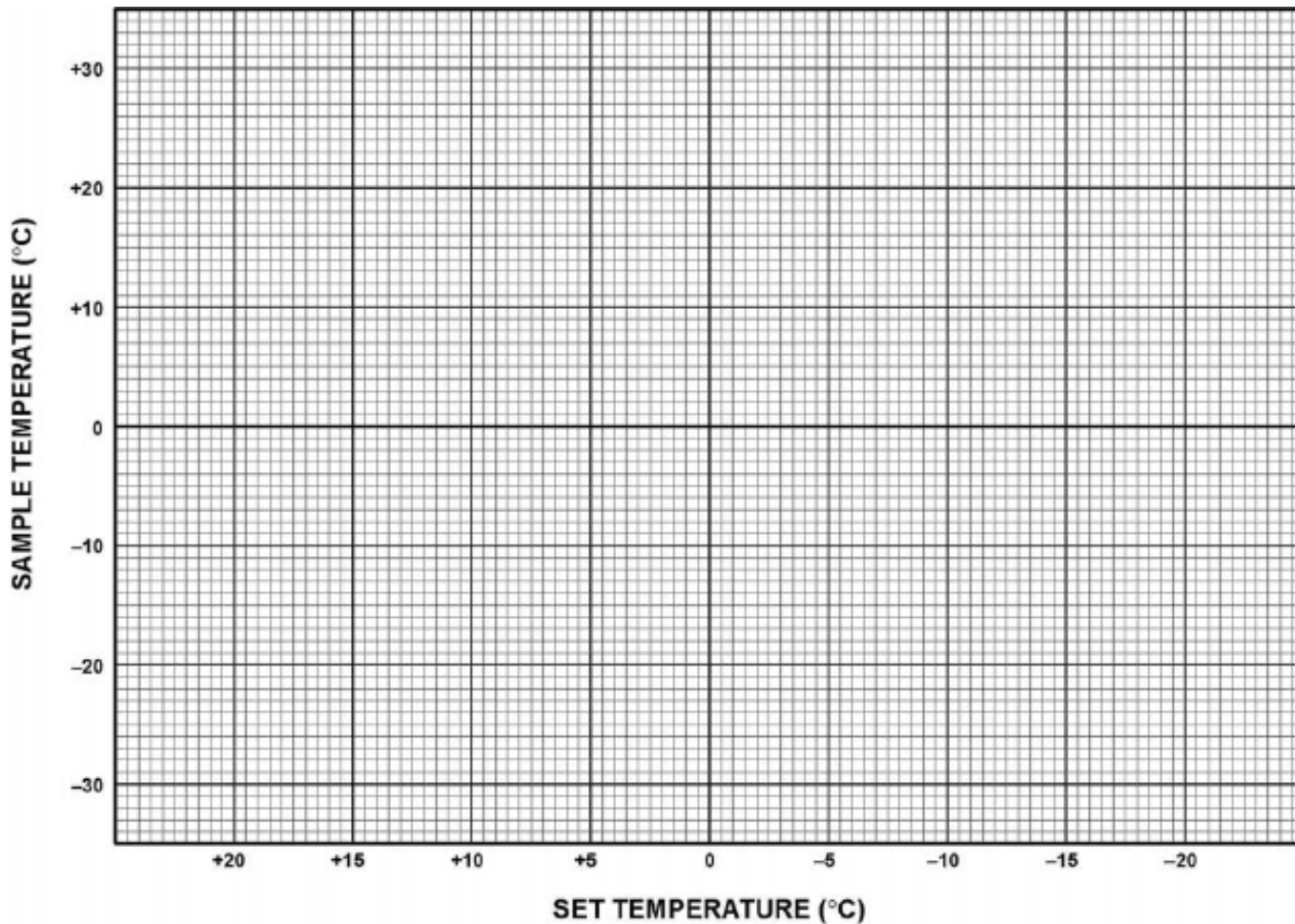

Rotor Speed/Temperature Differential Chart for

Rotor _____

Instrument _____

Ambient Temperature _____

Rotor Speed _____

DECONTAMINATION INFORMATION CERTIFICATE

Complete and attach to equipment **BEFORE** servicing (*instructions on reverse*)

PLEASE PRINT

DECONTAMINATION
CERTIFIED BY _____ TITLE/POSITION _____
PHONE _____ FAX _____ DEPARTMENT _____
INSTITUTION _____ ADDRESS _____
CITY _____ STATE _____ ZIP _____
INSTRUMENT _____ SERIAL NUMBER _____
ROTOR _____ SERIAL NUMBER _____
PART _____ PART NUMBER _____
HAZARDOUS CONTAMINANTS(S) _____ DECONTAMINATION DATE _____
DECONTAMINATION METHOD(S) _____
DECONTAMINATION
CERTIFIER'S SIGNATURE _____ DATE _____

DECONTAMINATION INFORMATION CERTIFICATE

Complete and attach to equipment **BEFORE** servicing (*instructions on reverse*)

PLEASE PRINT

DECONTAMINATION
CERTIFIED BY _____ TITLE/POSITION _____
PHONE _____ FAX _____ DEPARTMENT _____
INSTITUTION _____ ADDRESS _____
CITY _____ STATE _____ ZIP _____
INSTRUMENT _____ SERIAL NUMBER _____
ROTOR _____ SERIAL NUMBER _____
PART _____ PART NUMBER _____
HAZARDOUS CONTAMINANTS(S) _____ DECONTAMINATION DATE _____
DECONTAMINATION METHOD(S) _____
DECONTAMINATION
CERTIFIER'S SIGNATURE _____ DATE _____

DECONTAMINATION INFORMATION CERTIFICATE

Complete and attach to equipment **BEFORE** servicing (*instructions on reverse*)

PLEASE PRINT

DECONTAMINATION
CERTIFIED BY _____ TITLE/POSITION _____
PHONE _____ FAX _____ DEPARTMENT _____
INSTITUTION _____ ADDRESS _____
CITY _____ STATE _____ ZIP _____
INSTRUMENT _____ SERIAL NUMBER _____
ROTOR _____ SERIAL NUMBER _____
PART _____ PART NUMBER _____
HAZARDOUS CONTAMINANTS(S) _____ DECONTAMINATION DATE _____
DECONTAMINATION METHOD(S) _____
DECONTAMINATION
CERTIFIER'S SIGNATURE _____ DATE _____

INSTRUCTIONS

When an instrument that has been used with radioactive, pathogenic, or otherwise hazardous materials requires servicing by Thermo personnel either at the customer's laboratory or at Thermo facilities, the following procedure must be complied with to insure safety of our personnel:

1. The instrument or part to be serviced shall be cleaned of all blood and other encrusted material and decontaminated prior to servicing by our representative. No radioactivity shall be detectable by survey equipment.
2. A Decontamination Information Certificate shall be completed and attached to the instrument or part.

If an instrument or part to be serviced does not have a Decontamination Information Certificate attached to it, and, in our opinion, presents a potential radioactive or biological hazard, our representative will not service the equipment until proper decontamination and certification has been completed.

If an instrument is received at our Service facilities and, in our opinion, poses a radioactive or biological hazard, the sender will be contacted for instructions as to disposition of the equipment. Disposition costs will be borne by the sender.

Decontamination Information Certificates are included with these Operation Instructions. Additional certificates are available from your local technical or customer service representative. In the event these certificates are not available, a written statement certifying that the instrument or part has been properly decontaminated and outlining the procedures used will be acceptable.

NOTE Thermo Service representatives will indicate on a Customer Service Repair Report if decontamination was required, and if so, what the contaminate was and what procedure was used. If no decontamination was required, it should be so stated.

6/00

INSTRUCTIONS

When an instrument that has been used with radioactive, pathogenic, or otherwise hazardous materials requires servicing by Thermo personnel either at the customer's laboratory or at Thermo facilities, the following procedure must be complied with to insure safety of our personnel:

1. The instrument or part to be serviced shall be cleaned of all blood and other encrusted material and decontaminated prior to servicing by our representative. No radioactivity shall be detectable by survey equipment.
2. A Decontamination Information Certificate shall be completed and attached to the instrument or part.

If an instrument or part to be serviced does not have a Decontamination Information Certificate attached to it, and, in our opinion, presents a potential radioactive or biological hazard, our representative will not service the equipment until proper decontamination and certification has been completed.

If an instrument is received at our Service facilities and, in our opinion, poses a radioactive or biological hazard, the sender will be contacted for instructions as to disposition of the equipment. Disposition costs will be borne by the sender.

Decontamination Information Certificates are included with these Operation Instructions. Additional certificates are available from your local technical or customer service representative. In the event these certificates are not available, a written statement certifying that the instrument or part has been properly decontaminated and outlining the procedures used will be acceptable.

NOTE Thermo Service representatives will indicate on a Customer Service Repair Report if decontamination was required, and if so, what the contaminate was and what procedure was used. If no decontamination was required, it should be so stated.

6/00

INSTRUCTIONS

When an instrument that has been used with radioactive, pathogenic, or otherwise hazardous materials requires servicing by Thermo personnel either at the customer's laboratory or at Thermo facilities, the following procedure must be complied with to insure safety of our personnel:

1. The instrument or part to be serviced shall be cleaned of all blood and other encrusted material and decontaminated prior to servicing by our representative. No radioactivity shall be detectable by survey equipment.
2. A Decontamination Information Certificate shall be completed and attached to the instrument or part.

If an instrument or part to be serviced does not have a Decontamination Information Certificate attached to it, and, in our opinion, presents a potential radioactive or biological hazard, our representative will not service the equipment until proper decontamination and certification has been completed.

If an instrument is received at our Service facilities and, in our opinion, poses a radioactive or biological hazard, the sender will be contacted for instructions as to disposition of the equipment. Disposition costs will be borne by the sender.

Decontamination Information Certificates are included with these Operation Instructions. Additional certificates are available from your local technical or customer service representative. In the event these certificates are not available, a written statement certifying that the instrument or part has been properly decontaminated and outlining the procedures used will be acceptable.

NOTE Thermo Service representatives will indicate on a Customer Service Repair Report if decontamination was required, and if so, what the contaminate was and what procedure was used. If no decontamination was required, it should be so stated.

6/00

CHINA

Tel.: +86 21 68 65 45 88

Tel.: +86 10 58 50 35 88

INDIA

Tel.: +91 22 55 42 94 94

JAPAN

Tel.: +81 454 53 92 20

OTHER ASIA PACIFIC COUNTRIES

Tel.: +852 28 85 46 13

AUSTRIA

Tel.: +43 (1) 80 14 00

BELGIUM

Tel.: +32 24 82 30 30

FINLAND

Tel.: +35 89 32 91 00

FRANCE

Tel.: +33 1 69 18 77 77

+33 2 28 03 20 00

GERMANY

Tel.: +49 61 84 90 69 40

+49 61 03 40 81 012

ITALY

Tel.: +39 02 95 05 91

NETHERLANDS

Tel.: +31 7 65 71 44 40

SPAIN or PORTUGAL

Tel.: +34 9 32 23 31 54

SWITZERLAND

Tel.: +41 (1) 4 54 12 12

**UNITED KINGDOM
or IRELAND**

Tel.: +44 87 06 09 92 03

**Other EUROPE,
MIDDLE EAST, or
AFRICA**

Tel.: +49 61 84 90 69 40

+33 2 28 03 20 00

RUSSIA/CIS

Tel.: +7 09 52 25 11 15

UNITED STATES of AMERICA

Tel.: +1 800 522 77 46

+1 866 984 37 66

CANADA or LATIN AMERICA

Tel.: +1 800 522 77 46

+1 866 984 37 66

In Other Countries: Contact your local **Thermo Fisher Scientific** products distributor or agent.

Dans les autres pays: Contactez votre concessionnaire local des produits **Thermo Fisher Scientific** ou leur représentant.

In anderen Ländern: Wenden Sie sich an Ihren örtlichen **Thermo Fisher Scientific** Vertreter.

*E-mail Technical Service Representative for **Thermo Fisher Scientific** brand products at techsupport.led.asheville@thermofisher.com*

Visit our web site at <http://www.thermo.com>

Thermo
S C I E N T I F I C